



SAMSUNG

SPLIT-TYPE AIR CONDITIONER

	INDOOR UNIT	OUTDOOR UNIT
Model Code:	AR12HSSDPWKNEE AR09HSSDPWKNEE AR09HSFSPWKNEE AR12HSFSPWKNEE	AR12HSSDPWKXEE AR09HSSDPWKXEE AR09HSFSPWKXEE AR12HSFSPWKXEE
Basic Code:	AR12HSSDAWKNEU AR12HSSDAWKNEU AR12HSSDAWKNEU AR12HSSDAWKNEU	AR09FSFKBWTXEE AR09FSFKBWTXEE AR09FSFKBWTXEE AR09FSFKBWTXEE

SERVICE Manual

AIR CONDITIONER



CONTENTS

1. Precautions
2. Product Specifications
3. Alignment and Adjustments
4. Disassembly and Reassembly
5. Disassembly WIFI
6. Electrical Parts List
7. Wiring Diagram
8. PCB Diagram
9. Operating Instructions
10. Troubleshooting
11. Block Diagram
12. Reference Sheet

Contents

1. Precautions	1-1
1-1 Installing the air conditioner.....	1-1
1-2 Power supply and circuit breaker.....	1-1
1-3 During operation	1-1
1-4 Disposing of the unit.....	1-2
1-5 Others	1-2
2. Product Specifications	2-1
2-1 The Feature of Product	2-1
2-2 Product Specifications	2-2
2-3 The Comparative Specifications of Product.....	2-6
2-4 Accessory and Option Specifications	2-8
3. Alignment and Adjustments	3-1
3-1 Test Mode.....	3-1
3-2 Outdoor LED Display Error and Check Method	3-2
3-3 Setting Option Setup Method.....	3-5
3-4 Setting Option Setup Method.....	3-9
4. Disassembly and Reassembly	4-1
4-1. Indoor Unit.....	4-2
4-2. Outdoor Unit.....	4-12
5. Disassembly WIFI	5-1
5-1 WIFI Case.....	5-1
5-2 ASSY CONTROL IN	5-2
5-3 Assy Control Out	5-4
6. Electrical Parts List	6-1
6-1 INDOOR MAIN PBA	6-5
6-2 OUTDOOR MAIN PBA.....	6-11
6-3 ASSY WIFI PCB	6-20
7. Wiring Diagram	7-1
7-1 Indoor Unit.....	7-1
7-2 Outdoor Unit	7-2
7-3 ASSY WIFI KIT	7-3

Contents

8. PCB Diagram	8-1
8-1 Indoor PCB.....	8-1
8-2 Outdoor PCB	8-2
8-3 Wire connecting the indoor unit terminal blocks	8-8
9. Operating Instructions.....	9-1
9-1 Name of Each Part	9-1
9-2 Wireless Remote Control-Buttons and Display.....	9-2
10. Troubleshooting	10-1
10-1 Items to be checked first.....	10-1
10-2 Communication Error	10-2
10-3 PCB Inspection Method.....	10-37
10-4 ASSY WIFI KIT Inspection Method.....	10-39
11. Block Diagram	11-1
11-1 Indoor unit	11-1
11-2 Outdoor unit.....	11-2
12. Reference Sheet.....	12-1
12-1 Low Refrigerant Pressure Distribution.....	12-1
12-2 Pressure & Capacity mark.....	12-1
12-3 Q & A for Non-trouble.....	12-2
12-4 Cleaning /Filter Change.....	12-5
12-5 Installation.....	12-6
12-6 Installation Diagram of Indoor Unit and Outdoor Unit.....	12-7
12-7 Working Range.....	12-9
12-8 Reference Sheet.....	12-10

1. Precautions

1-1 Installing the air conditioner

- Uses should not install the air conditioner by themselves.
Ask the dealer or authorized company to install the air conditioner except window-type air conditioner in U.S.A and Canada.
- If you don't install the air conditioner properly, it may cause a fire, a water leakage or an electric shock.
- You must install the air conditioner according to the national wiring regulations and safety regulations.
- Install the indoor unit higher than 2.5m from the floor to avoid the injury caused by the operation of the fan.
(except the window-type air conditioner)
- The manufacturer is not responsible for any accidents or injury caused by an incorrect installation.
- When installing the built-in type air conditioner, keep all electric cables such as the power cable and the connection cord in pipes, ducts, or cable channels to protect them from the danger of impact or any other incidents.

1-2 Power supply and circuit breaker

- If the power cord of the air conditioner is damaged, it must be replaced by the manufacturer or a qualified person in order to avoid a hazard.
- The air conditioner must be plugged into an independent circuit if applicable or connect the power cable to the auxiliary circuit breaker.
An all pole disconnection form the power supply must be incorporated in the fixed wiring with a contact opening of >3mm.
- Do not extend an electric cord to the air conditioner.
- The air conditioner must be plugged in after you complete the installation.

1-3 During operation

- Do not repair the air conditioner at your discretion.
It is recommended to contact a service center directly.
- Never spill any kind of liquid on the air conditioner.
If this happens, turn off the air conditioner and contact an authorized service center.
- Do not insert anything between the airflow blades to prevent damage of the inner fan and consequent injury.
Keep children away from the air conditioner.
- Do not place any obstacles in front of the air conditioner.
- Do not spray any kind of liquid into the indoor unit. If this happens, turn off the air conditioner and contact a service center.
- Make sure that the air conditioner is well ventilated at all times.
Do not place a cloth or other materials over it.
- Remove the batteries if you don't use the remote control for a long time. (If applicable)
- Use the remote control within 7 meters from the indoor unit. (If applicable)

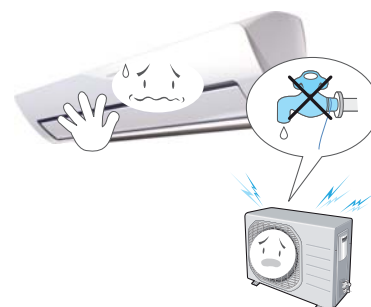

1-4 Disposing of the unit

- Before the throwing out the air conditioner, remove the batteries from the remote control.
- When you dispose of the air conditioner, consult your dealer. If pipes are removed incorrectly, refrigerant may blow out and cause air pollution. When it contacts with your skin, it can cause skin injury.
- The package of the air conditioner should be recycled or disposed of properly for environmental reasons.

1-5 Others

- Never store or load the air conditioner upside down or sideways to prevent the damage to the compressor.
- Young children or infirm persons should be always supervised when they use the air conditioner.
- Max current is measured according to IEC standard for safety.
- Current is measured according to ISO standard for energy efficiency.

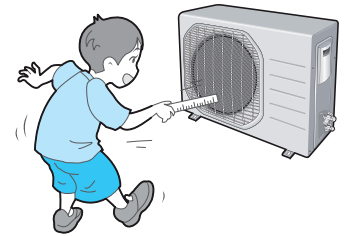

2. Product Specifications









2-1 The Feature of Product

- 2 step cooling
 - Get cool quickly and keep cool comfortably without shivering
- Single user mode
 - No worrying about the electricity bill, even using it when you're alone.
- Crystal gloss design
 - Uniquely stylish and innovative design to enhance your life and home
- Smart Wi-Fi
 - Control air conditioner anytime and anywhere
- Smart Installation
 - Get the confidence that it's perfectly installed
- Smart Check
 - Don't worry about the trouble-shooting in your home
- Triple Protector Plus
 - Use longer without damage in unsuitable conditions
- Easy Installation
 - Secure the easy Installation of Indoor unit and pipe connection
- Easy Filter
 - Quick and easy to clean filter saves time and effort









2-2 Product Specifications

ITEM				MODEL		AR09HSSDPWK/EE		AR12HSSDPWK/EE		AR09HSFSPWK/EE		AR12HSFSPWK/EE	
				Indoor Unit	Outdoor Unit	Indoor Unit	Outdoor Unit	Indoor Unit	Outdoor Unit	Indoor Unit	Outdoor Unit		
Type				Wall-mounted	Wall-mounted	Wall-mounted	Wall-mounted	Wall-mounted	Wall-mounted	Wall-mounted	Wall-mounted	Wall-mounted	
Performance	Capacity	Cooling	KW	0.9/2.5/3.3		0.9/3.5/4.0		0.9/2.5/3.3		0.9/3.5/4.0			
		Heating	(Low/Std/Max)	0.8/3.2/6.3		0.8/4.0/7.0		0.8/3.2/6.3		0.8/4.0/7.0			
	Running Frequency	Cooling	Hz	12/29/44		12/48/60		12/29/44		12/48/60			
		Heating	(Low/Std/Max)	12/43/95		12/55/112		12/43/95		12/55/112			
	Noise	Sound Pressure	dB	38/17	44	40/17	45	38/17	44	40/17	45		
		Sound Power	(H/L)	56	59	56	62	56	59	58	62		
	Energy Efficiency Ratio	Cooling	W/W	5.05		4.22		4.81		4.17			
Heating		(Std)	5.16		4.4		5		4.21				
Power		ph-V-Hz	1phase, 220-240V~, 50Hz		1phase, 220-240V~, 50Hz		1phase, 220-240V~, 50Hz		1phase, 220-240V~, 50Hz				
Pow	Power Consumption	Cooling	KW	0.2/0.495/0.75		0.2/0.83/1.11		0.2/0.52/0.75		0.2/0.84/1.11			
		Heating	(Low/Std/Max)	0.17/0.62/1.85		0.17/0.91/2.2		0.17/0.64/1.85		0.17/0.95/2.2			
	Operating Current	Cooling	A	1.4/2.4/3.6		1.4/3.9/5.1		1.4/2.6/3.6		1.4/4.1/5.1			
		Heating	(Low/Std/Max)	1.0/3.3/8.5		1.0/4.4/9.5		1.0/3.5/8.5		1.0/4.6/9.5			
Power Factor	Cooling	%	70/90/91		70/90/94		70/90/91		70/90/94				
	Heating	(Low/Std/Max)	70/90/95		70/90/95		70/90/95		70/90/95				
Size	Gross Dimension	W*D*H	mm	956*335*317	926*640*384	956*335*317	926*640*384	956*335*317	926*640*384	956*335*317	926*640*384		
	Weight(Net)		kg	11.5	35.5	11.5	35.5	11.5	35.5	11.5	35.5		
	Refrigerant Pipe	Liquid	mm	6.35 (1/4 inch)		6.35 (1/4 inch)		6.35 (1/4 inch)		6.35 (1/4 inch)			
		Gas	mm	9.52 (3/8 inch)		9.52 (3/8 inch)		9.52 (3/8 inch)		9.52 (3/8 inch)			
	Drain Hose		L*D	550±20		550±20		550±20		550±20			
	Compressor	Type		DA128A1FA-20F(Toshiba)		DA128A1FA-20F(Toshiba)		DA128A1FA-20F(Toshiba)		DA128A1FA-20F(Toshiba)			
		Motor	Type	HERMETIC		HERMETIC		HERMETIC		HERMETIC			
			Rated Output(W)	-		-		-		-			
	Oil Type			-		-		-		-			
	Blower	Type		CROSS-FLOW	PROPELLER	CROSS-FLOW	PROPELLER	CROSS-FLOW	PROPELLER	CROSS-FLOW	PROPELLER		
motor		Type	BLDC	BLDC	BLDC	BLDC	BLDC	BLDC	BLDC	BLDC			
Heat Exchanger			2ROWx14STEPx705, 1-2Path	2ROWx24STEPx(850+825), 4-2-2Path	2ROWx14STEPx705, 1-2Path	2ROWx24STEPx(850+825), 4-2-2Path	2ROWx14STEPx705, 1-2Path	2ROWx24STEPx(850+825), 4-2-2Path	2ROWx14STEPx705, 1-2Path	2ROWx24STEPx(850+825), 4-2-2Path			
Refrigerant Control Unit			R410A		R410A		R410A		R411A				
Freezer Oil Capacity		cc	-		-		-		-				
Refrigerant to Change(R410A)		g	1200		1200		1200		1200				
Protection Device(OLP)			-		-		-		-				
Operation condition range	Cooling		-15~46(cooling)		-15~46(cooling)		-15~46(cooling)		-15~46(cooling)				
	Heating		-25~24(heating)		-25~24(heating)		-25~24(heating)		-25~24(heating)				

2-3 The Comparative Specifications of Product

ITEM		MODEL	Develop Model			
			AR09HSSDPWK/EE	AR12HSSDPWK/EE	AR09HSFSPWK/EE	AR12HSFSPWK/EE
Design	Indoor Unit					
	Outdoor Unit					
Net Weight	Indoor Unit	11.5	11.5	11.5	11.5	
	Outdoor Unit	35.5	35.5	35.5	35.5	
Outer Dimension	Indoor Unit	956*335*317	956*335*317	956*335*317	956*335*317	
	Outdoor Unit	926*640*384	926*640*384	926*640*384	926*640*384	
Noise	Indoor Unit	38/17(Sound Pressure) /56(Sound Power)	40/17(Sound Pressure) /58(Sound Power)	38/17(Sound Pressure) /56(Sound Power)	40/47(Sound Pressure) /58(Sound Power)	
	Outdoor Unit	44(Sound Pressure)/59(Sound Power)	45(Sound Pressure)/62(Sound Power)	44(Sound Pressure)/59(Sound Power)	45(Sound Pressure)/62(Sound Power)	
Air Purifying System	Filter	FULL HDFILTER	FULL HDFILTER	FULL HDFILTER	FULL HDFILTER	

2-4 Accessory and Option Specifications

Item	Descriptions	Code-No.	Q'TY	Remark
	Installation Plate	DB90-07732A	1	Indoor unit case
	Remote controller	DB93-14643C	1	
	Batteries for Remote controller	4301-000121	2	
	User's & Installation Manual	DB68-04222A	1	
	Wi-Fi Manual	DB68-04221A	1	
	M4x10 Tapped Screws	DB97-23032A	2	
	M4 x 16 Tapped Screws	DB97-11984A	2	
	Drain Plug	DB67-20011A	1	Outdoor unit case
	Rubber Leg	DB73-20134A	4	

3. Alignment and Adjustments

3-1 Test Mode

■ How to Approach Test Mode

You can approach the test mode by pressing the on/off switch of indoor unit for 5 seconds.



■ Test mode operation option

After installing the air conditioner, check whether each subordinate is normally operated or not by operating the test mode.

- **When an Error occurs, display the Error Mode.**
- **Operation Mode :** Cool mode. operate the cool mode by operating the compressor by force without the compressor ON/OFF according to the set temperature/indoor temperature. (Do not follow the antifreeze control)
- **Up-down louver :** Up-down swing mode
- **Indoor Fan :** Turbo



Note

- Because the test mode operates the cool mode by force not related to the set temperature / indoor temperature, check whether each subordinate is operated normally or not after completing installation and must turn off the power of the air conditioner.

3-2 Display Error and Check Method

3-2-1 Indoor Display Error and Check Method

ERROR MODE	DESCRIPTION
E101 / E102	Communication Error (Indoor Outdoor)
E121	ROOM TH sensor error
E122	INDOOR MID, INDOOR IN PIPE-TH sensor error
E154	Fan Error (Indoor)
E162	EEPROM Error (Indoor)
E163	Option Error
E203	Time out Comm. (Inv Micom ↔ Main Micom)
E221	OUT-TH(Outdoor Temperature) Sensor Error
E231	CON-TH(Cond Temperature) Sensor Error
E251	DIS-TH(Discharge Temperature) Sensor Error
E416	DIS-TH(Discharge Temperature) Over Error
E422	EEV or Valve Close error-Self diagnosis
E440	Prohibit Operation Condition Error (Heating)
E441	Prohibit Operation Condition Error (Cooling)
E458	Fan Error(Outdoor)
E461	Comp Starting Error
E462	AC Input I_Limit Trip Error
E464	IPM Over Current(O.C) Error
E465	Comp V_limit/I_limit Error
E466	DC-Link Voltage Under/Over Error
E467	Comp Wire Missing Error
E468	Current Sensor Error
E469	DC-Link Voltage Sensor Error
E470	EEPROM Data Error (no data)
E471	EEPROM Data Error (Main Micom ↔ Inv Micom)
E474	Heatsink Sensor Error
E483	Over Voltage Protection Error
E484	PFC Over Load Error
E485	Input Current Sensor Error
E488	AC Input Voltage Sensor Error
E500	Heatsink Over Temperature Error
E554	Gas Leak Error

7-SEG	ERROR MODE			DESCRIPTION
	LED1 OPERATION	LED2 TIMER	LED3 OPTION	
E101, E102	○	●	●	Communication error (indoor ↔ outdoor)
E121	○	●	○	ROOM TH sensor error
E122, E123	●	●	○	INDOOR MID, INDOOR IN PIPE-TH sensor error
E154	○	○	●	Fan error(indoor)
E162	●	●	●	EEPROM error
E163	●	●	●	Option error
FROM E200	●	○	●	Outdoor error display
E422	●	○	●	EEV or Valve Close error-Self diagnosis

● : LAMP ON ○ : LAMP OFF ● (with dot) : LAMP BLINK

* Note *

If the Set doesn't work (No power), check the Thermal fuse of Terminal block OPEN or SHORT with Multimeter.

* Measure the Thermal fuse housing PIN#1 ~ 2 :
OPEN(disconnection) -> defective product

Outdoor LED Display Error and Check Method (12K/18K/24K)

LED PATTERN			DESCRIPTION
YEL	GRN	RED	
○	○	○	Power off/VDD NG
●	●	●	Power ON reset(1sec)
○	◉	●	Normal Operation
○	○	●	Abnormal Communication (Indoor↔Outdoor)
○	●	●	
○	○	◉	IPM Over Current (O.C) Error
○	◉	○	Comp Starting Error
○	●	○	EEPROM Data Error (no data)
○	●	◉	DC-Link Voltage Under/Over Error
			PFC Over Load Error
			Over Voltage Protection Error
◉	○	◉	OUT-TH(Outdoor Temperature) Sensor Error
◉	○	●	DIS-TH(Discharge Temperature) Over Error
◉	◉	○	DIS-TH(Discharge Temperature) Sensor Error
◉	◉	●	Current Sensor Error
			Heatsink Sensor Error
			Input Current Sensor Error
◉	●	○	Comp V_limit/I_limit Error
			Heatsink Over Temperature Error
◉	●	◉	CON-TH(Cond Temperature) Sensor Error
◉	●	●	Time out Comm. (Inv Micom↔Main Micom)
●	○	○	Fan Error(Outdoor)
●	○	◉	EEPROM Data Error (Main Micom↔Inv Micom)
●	○	●	Comp Wire Missing Error
●	◉	○	Prohibit Operation Condition Error (Heating)
			Prohibit Operation Condition Error (Cooling)
●	◉	◉	DC-Link Voltage Sensor Error
			AC Input Voltage Sensor Error
●	◉	●	AC Input I_Limit Trip Error
●	●	○	Gas Leak Error
			EEV or Valve Close error-Self diagnosis
○	◉	◉	Test Operation at Cooling Mode
◉	◉	◉	Test Operation at Heating Mode

● LED ON, ○ LED OFF, ◉ LED BLINKING

3-3 Setting Option Setup Method

ex) Option No. :

Note :



SEG1, SEG7, SEG13, SEG19 need not to be pressed in, so in fact the Option No. we should press in is as below.

30 00 07 C2 6C 83 10 00 00 00 20 00 00 00 00 00 00 10 00 00

SEG1	SEG2	SEG3	SEG4	SEG5	SEG6	SEG7	SEG8	SEG9	SEG10	SEG11	SEG12	SEG13	SEG14	SEG15	SEG16	SEG17	SEG18	SEG19	SEG20	SEG21	SEG22	SEG23	SEG24	
0	3	0	0	0	0	1	7	C	2	6	C	2	8	3	1	0	0	3	0	0	0	0	0	
SEG25	SEG26	SEG27	SEG28	SEG29	SEG30	SEG31	SEG32	SEG33	SEG34	SEG35	SEG36	SEG37	SEG38	SEG39	SEG40	SEG41	SEG42	SEG43	SEG44	SEG45	SEG46	SEG47	SEG48	
0	2	0	0	0	0	1	0	0	0	0	0	2	0	0	0	0	1	3	0	0	0	0	0	

Step 1



























Enter the Option Setup mode.

- Tack out the batteries of remote control.
- Press the temperature  button simultaneously and insert the battery.
- Make sure the remote control display shown as  .



Step 2

Enter the Options Setup mode and select your options according to the following procedure.

	Feature	Display
	<p>1 The default value is  .</p> <p>Every time you push the  button, the display panel reads  Auto → Cool → Dry → Fan → Heat,  Auto → Cool → Dry → Fan → Heat repeatedly.</p>	
	<p>2 Push the  button to set the display panel to 3.</p> <p>Every time you push the  button, the display panel reads 0→1→2→3→.....→9→A→b→c→d→E→F repeatedly.</p>	
	<p>3 Push the  button to  .</p> <p>Every time you push the  button, the display panel reads 0→1→2→3→.....→9→A→b→c→d→E→F repeatedly.</p>	
	<p>4 Push the  button to  .</p> <p>Push the  button to set the display panel to 7.</p> <p>Every time you push the  button, the display panel reads 0→1→2→3→.....→9→A→b→c→d→E→F repeatedly.</p>	
	<p>5 Push the  button to  .</p> <p>Push the  button to set the display panel to C.</p> <p>Every time you push the  button, the display panel reads 0→1→2→3→.....→9→A→b→c→d→E→F repeatedly.</p>	
	<p>6 Push the  button to set the display panel to 2.</p> <p>Every time you push the  button, the display panel reads 0→1→2→3→.....→9→A→b→c→d→E→F repeatedly.</p>	

	Feature	Display
	<p>7 Push the button to . Push the button to set the display panel to 6. Every time you push the button, the display panel reads 0 → 1 → 2 → 3 → → 9 → A → b → c → d → E → F repeatedly.</p>	
	<p>8 Push the button to set the display panel to 8. Every time you push the button, the display panel reads 0 → 1 → 2 → 3 → → 9 → A → b → c → d → E → F repeatedly.</p>	
	<p>9 Push the button to . Push the button to set the display panel to 8. Every time you push the button, the display panel reads 0 → 1 → 2 → 3 → → 9 → A → b → c → d → E → F repeatedly.</p>	
	<p>10 Push the button to set the display panel to 3. Every time you push the button, the display panel reads 0 → 1 → 2 → 3 → → 9 → A → b → c → d → E → F repeatedly.</p>	
	<p>11 Push the button to . Push the button to set the display panel to 1. Every time you push the button, the display panel reads 0 → 1 → 2 → 3 → → 9 → A → b → c → d → E → F repeatedly.</p>	
	<p>12 Push the button to .</p>	
	<p>13 Push the button to .</p>	
	<p>14 Push the button to .</p>	

Step 3 Upon completion of the selection, check you made right selections.

Press the Mode (Mode) Selection key to set the display part and check the display part.
→ The display part shows like below when each time you press Mode button.





































Step 4 Pressing the ON/OFF button (Power) .

When pressing the operation ON/OFF key with the direction of remote control for unit, the sound ' rōing' or ' ' and the OPERATION ICON () lamp of the display is flickering at the same time, then the input of option is completed. (If the deriving sound isn' t heard, try again pressing the ON/OFF button.)

Step 5

Enter the Options Setup mode and select your options according to the following procedure.

	Feature	Display
	1 Step 1 (Enter the Option Setup mode) is executed. (Seg25 ~ 48 for setting remote control Setup)	
	2 Push the  Mode button to set the display panel to 2. Every time you push  button, the display panel reads Auto - 2 - 3 - . 9 - A - b - c - d - E - F repeatedly.	
	3 Push the  button to 	
	4 Push the  button to 	
	5 Push the  button to 	
	6 Push the  button to 	
	7 Push the  button to 	
	8 Push the  button to 	
	9 Push the  button to 	
	10 Push the  Mode button to set the display panel to 1. Every time you push  button, the display panel reads Auto - 2 - 3 - . 9 - A - b - c - d - E - F repeatedly.	
	11 Push the  button to 	
	12 Push the  button to 	

Step 6 Upon completion of the selection, check you made right selections.

Press the Mode  Selection key to set the display part and check the display part.
 → The display part shows like below when each time you press Mode button.



Step 7 Pressing the ON/OFF button ) .

When pressing the operation ON/OFF key with the direction of remote control for unit, the sound ' ' Ding' ' or ' ' Diriring' ' is heard and the OPERATION ICON () lamp of the display is flickering at the same time, then the input of option is completed. (If the deriving sound isn' t heard, try again pressing the ON/OFF button.)

Step 8 Unit operation test-run.

- First: Remove the battery from the remote control.
- Second : Re-insert the battery into the remote control.
- Third : Press ON/OFF key with the direction of remote control for set.

■ Error mode

1. If all lamps of indoor unit are flickering, Plug out, plug in power plug again and press ON/OFF key to retry.
2. If the unit is not working properly or all lamps are continuously flickering after setting the option code, see if the correct option code is set up for its model.

□ Option Items

Model	Option
AR09HSSDPWK/EE	011045-176A47-271920-37C63F / 033B37-101E2B-200000-300000
AR12HSSDPWK/EE	011045-156A69-272328-37C83F / 034340-103037-200000-300000
AR09HSFSPWK/EE	010005-176A47-271920-37C63F / 033B37-101E2B-200000-300000
AR12HSFSPWK/EE	010005-156A69-272328-37C83F / 034340-103037-200000-300000

3-4 EEPROM Download (485 communication model)

Method#1 : Using Communication line

1) Power off

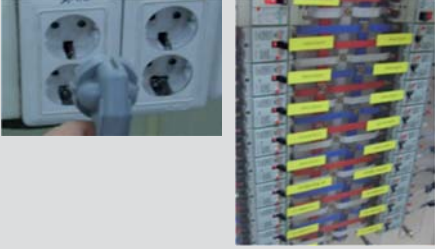

2) Take off the side cover



3) Connect PC-Download Jig-PBA

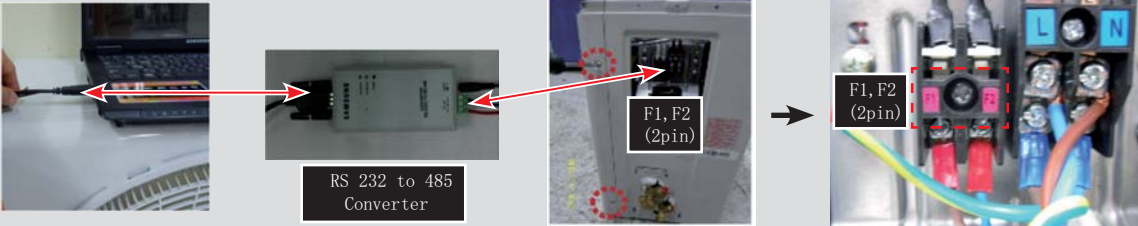

4) Execute the Inverter Download program



5) Select COM Port and connect



6) Open the file (*.src)

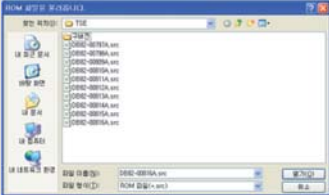

7) Click the Start button and reset the power

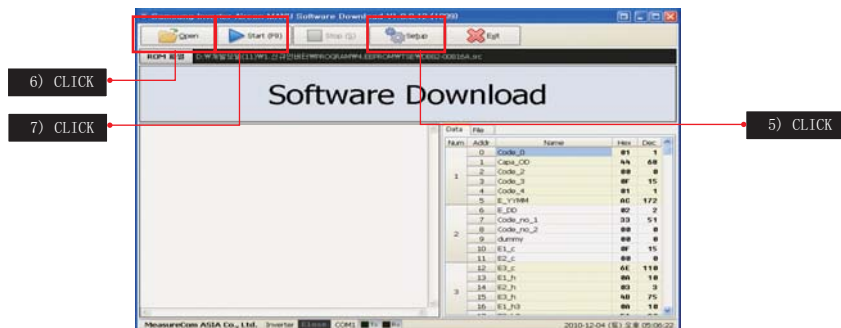

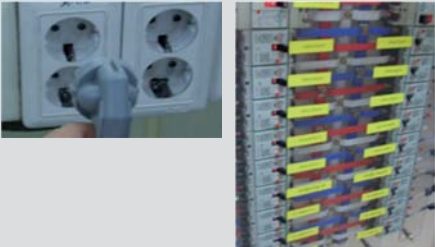

Method#2 : Using Serial line

1) Power off



2) Take off the Cabinet : Check the LED off



3) Connect PC-Download Jig-PBA



Download connector (10pin, Black)

- 1) DB41-01010A : CN201
- 2) DB41-01129A : CN201
- 3) DB41-01023A : CN512
- 4) DB41-01081B : CN37

PIN# 1:RXD, 2:TXD, 9:GND, 10:VCC

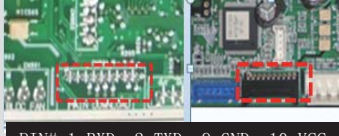

Download connector (20pin, Black)

- 1) DB41-01227A : CN201
- 2) DB41-01228A : CN201

PIN# 1:RXD, 2:TXD, 9:GND, 10:VCC



4) Execute the Inverter Download program



5) Select COM Port and connect

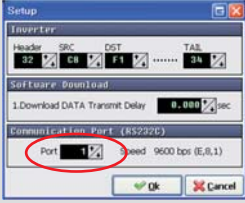

6) Open the file(*.src)

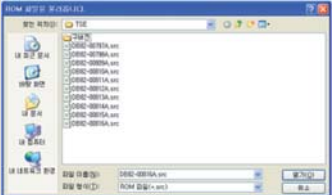

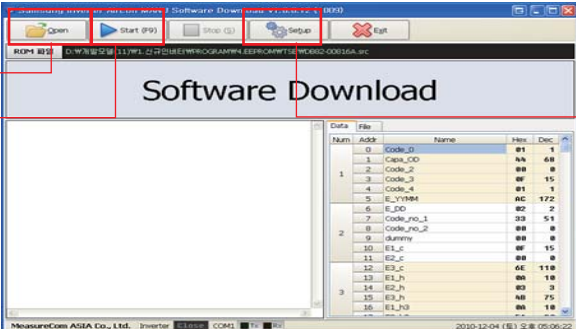

7) Click the Start button





Num	Addr	Name	Hrs	Dec
0	Code_0		01	1
1	Code_1	Capa_CD	0A	68
2	Code_2		0B	8
3	Code_3		0F	15
4	Code_4		01	1
5	E_VVbM		0C	172
6	E_P0		02	2
7	Code_no_1		33	51
8	Code_no_2		00	8
9	dummy		00	8
10	ET_c		0F	15
11	ET_c		00	8
12	ET_c		4E	110
13	ET_h		00	10
14	ET_h		00	3
15	ET_h		0B	75
16	ET_h		00	10









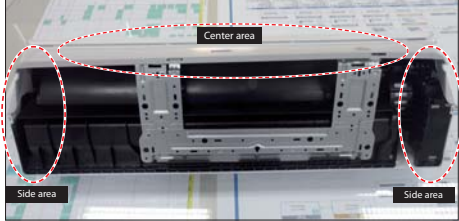

4. Disassembly and Reassembly



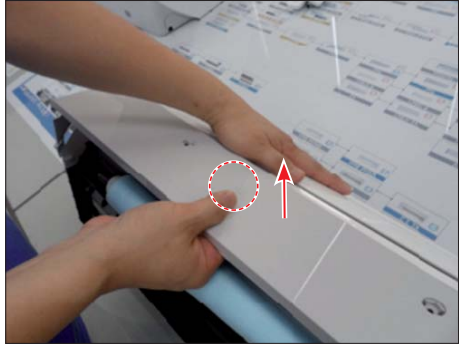

■ Necessary Tools

Item	Remark
+SCREW DRIVER	
MONKEY SPANNER	
-SCREW DRIVER	

4-1. Indoor Unit

No	Parts	Procedure	Remark
1	PANEL-FRONT	<p>1) Stop the driving of air conditioner and shut off main power supply.</p> <p>2) Detach FILTER PRE from the PANEL FRONT.</p> <p>3) Cover Panel is assembled on bottom of indoor unit as shown in the figure. Remove the Cap Screw as shown on the right side and then remove the screw and separate the Cover Panel.</p>	   

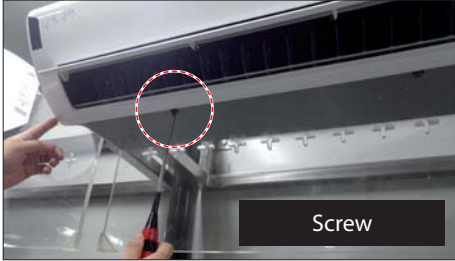
No	Parts	Procedure	Remark						
		<p>4) Cover Panel is fixed to body by Hook in center area and side area.</p> <p>5) Separate the hook after pushing both end of Cover Panel as shown in the figure. (Watch out for the damage of the hook)</p> <p>6) Raise front part upward obliquely as shown in the figure and then remove the hooks.</p>	 <table border="1" data-bbox="938 577 1398 734"> <thead> <tr> <th colspan="2">HOOK</th> </tr> </thead> <tbody> <tr> <td>9/12K</td> <td></td> </tr> <tr> <td>18/24/30K</td> <td></td> </tr> </tbody> </table>   	HOOK		9/12K		18/24/30K	
HOOK									
9/12K									
18/24/30K									

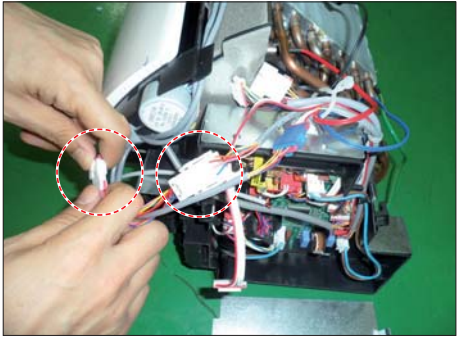
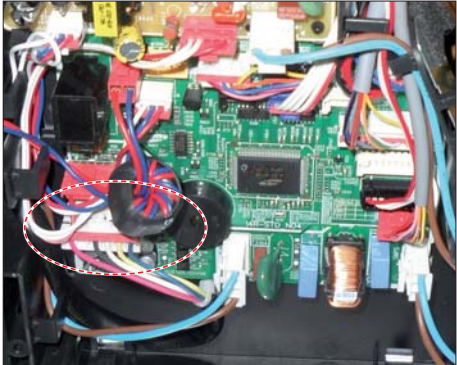
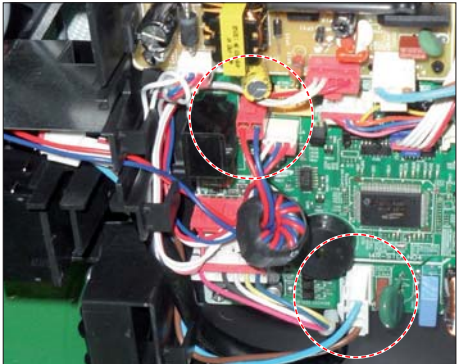
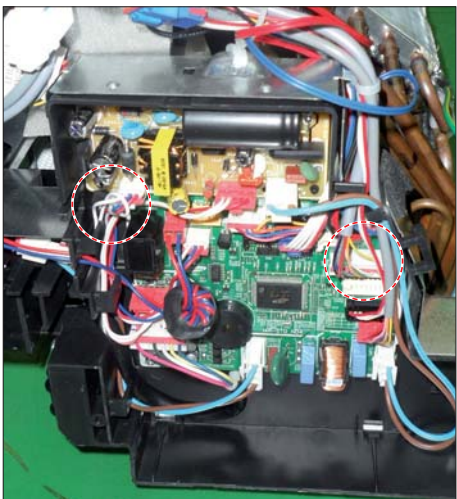

No	Parts	Procedure	Remark
		<p>⚠ Caution: Assembly of Cover Panel after service end.</p> <ul style="list-style-type: none"> - Reassembly is in the reverse order of the removal. - Piping and drain hose must be careful not to damage and Progress must be done with both hands. 	    

No	Parts	Procedure	Remark
		<p>7) To detach the PANEL-FRONT from the main frame, unfasten 2 screws at the bottom. (use + Screw Driver)</p> <p>8) To detach the COVER-PANEL from the main frame, loosen 4 HOOK Structures. When separate the hook : Use the (-) screw Driver. (-)Screw Driver Insert the hook and then pull the hook as shown on the right side. (Watch out for the damage of the hook)</p>	   

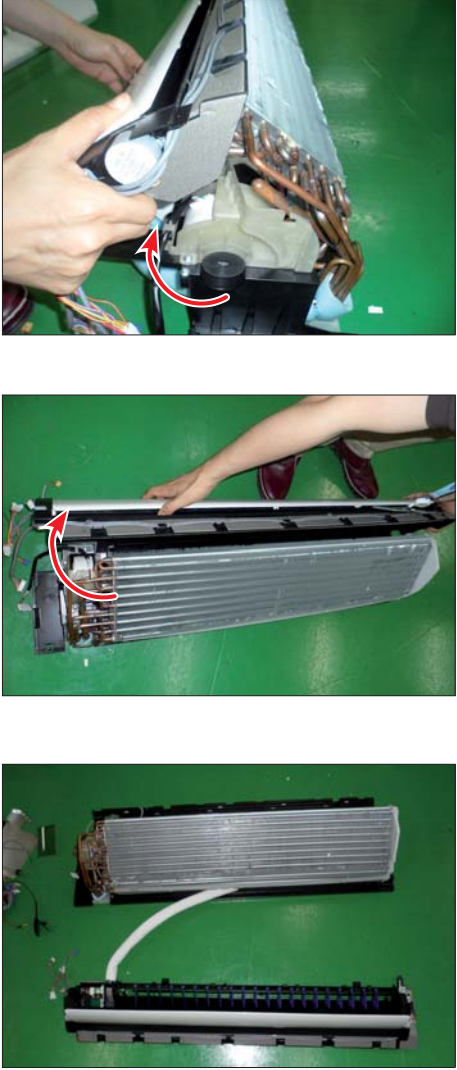
No	Parts	Procedure	Remark
2	CONTORLIN	<p>5) Loosen Stepping MOTOR Wire / BLADE Wire.</p> <p>6) Loosen MOTOR Wire. ⚠ Caution: When you separate the connector, pull pressing the locking button.</p> <p>7) Loosen the terminal block wires. ⚠ Caution: When you separate the connector, pull pressing the locking button.</p> <p>8) Loosen the Thermistor wire connector, Display wire connector. ⚠ Caution: When you separate the connector, pull pressing the locking button.</p>	   

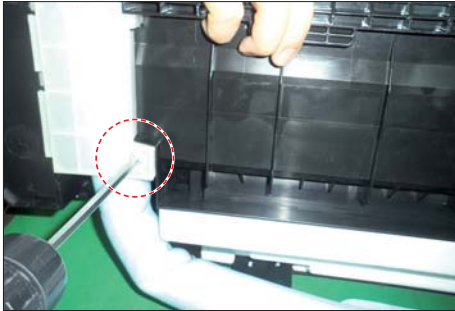

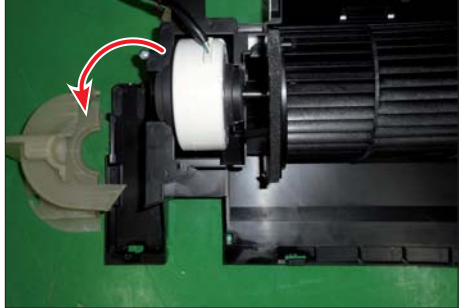

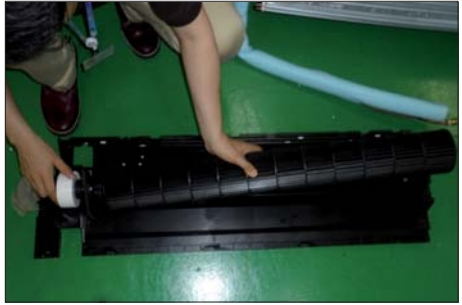
No	Parts	Procedure	Remark
5	EVAPORATOR	9) Take off the CASE-CONTROL from the main frame after loosen the remaining connector. ⚠ Caution: When you separate the connector, pull pressing the locking button.	
3	TRAY DRAIN	1) To detach TRAY-DRAIN from the main frame, pull the bottom of the TRAY-DRAIN towards you.	



No	Parts	Procedure	Remark
4	Evaporator	<p>1) Detach the HOLDER PIPE.</p> <p>2) Unfasten the screw at the left side. (use + Screw Driver)</p> <p>3) Unfasten the screw at the right side. (use + Screw Driver)</p> <p>4) To detach Evaporator from the main frame, pull the bottom of the Evaporator towards you.</p>	   



No	Parts	Procedure	Remark
5	FAN MOTOR & CROSS FAN	<p>1) Unfasten the screw. (use + Screw Driver)</p> <p>2) Detach the FAN Motor case.</p> <p>3) Unfasten the screw a little. (use + Screw Driver)</p> <p>4) Pull the CROSS-FAN to the left side.</p>	   



No	Parts	Procedure	Remark
6	Assy SPI Lamp	<p>1) Remove the Assy SPI Lamp from the Back Body as shown on the right side.</p> <p>⚠ Caution.</p> <ul style="list-style-type: none"> - Confirm Seal of backside necessarily after replace of Assy SPI Lamp. - Seal should be close adhesion to SPI Lamp. - Measure as shown on the right side since replace. <p>(If the seal is not close adhesion perfectly : Defectiveness can happen)</p>	



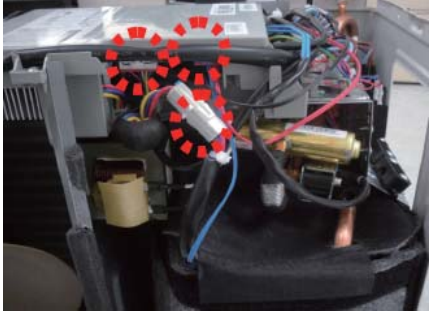
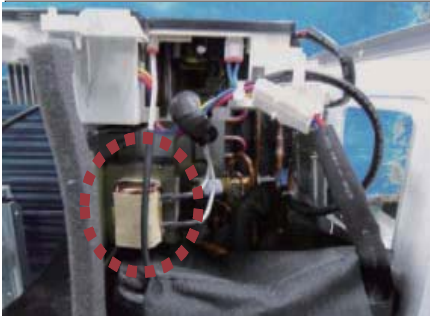

4-2 Outdoor Unit

No	Parts	Procedure	Remark
1	Common Work	<p>1) Loosen 1 fixing screw(CCW) of the Cover-Side. (Use +Screw Driver.)</p> <p>2) Loosen each 5 screws(CCW) on both right and left Cabinet Side edges and a fixing screw on the Cabinet Front lower to detach the Cabinet Front. (Use +Screw Driver.)</p> <p>3) Detach the Cabinet Upper like the picture.</p> <p>4) Loosen 2 screw(CCW) fixed to assemble Plate Control Out with Cabinet-Side RH. (Use +Screw Driver.)</p>	   

No	Parts	Procedure	Remark
1	Common Work	<p>5) Loosen 2 screw(CCW) on the right side of Cabinet Front. (Use +Screw Driver)</p> <p>6) Loosen 2 screw(CCW) on the left side of Cabinet Front. (Use +Screw Driver)</p> <p>7) Loosen 3 screw(CCW) on the front side of Cabinet Front. (Use +Screw Driver)</p>	  

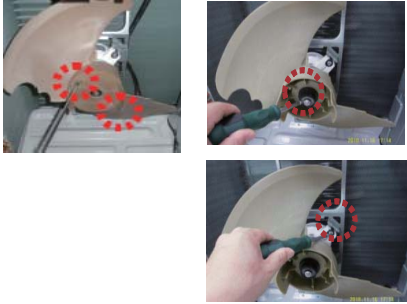

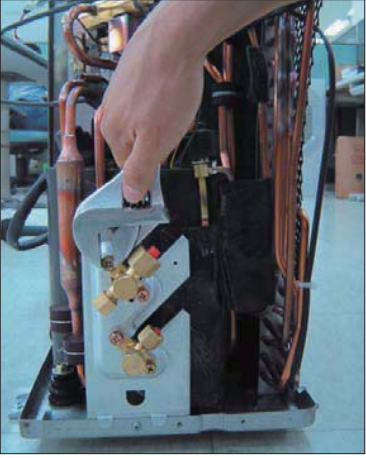

No	Parts	Procedure	Remark
		<p>8) Loosen 4 fixing screws(CCW) on the rear side of Cabinet-Side RH. (Use +Screw Driver.)</p> <p>9) Loosen 3 screws(CCW) fixed to assemble Bracket Valve with Cabinet-Side RH. (Use +Screw Driver.)</p>	 

No	Parts	Procedure	Remark
2	Ass'y Control Out	<ol style="list-style-type: none"> 1) Detach the Motor Wire from the PCB of Ass'y Control Out. 2) Detach several connectors from the PCB of Ass'y Control Out. 3) Detach 2 Connect Wires from Reactor. 4) Loosen 1 screw(CCW) fixed to assemble Ass'y Control Out with Partition. (Use +Screw Driver.) 	   

No	Parts	Procedure	Remark
3	Fan & Motor	<ol style="list-style-type: none"> 1) Release 2 screw at CAP FAN 2) Release Nut at Fan Boss 3) Release 3 screws st Motor Bracket. 4) Detach Motor Wire from the Assy Control Out. 	
4	Heat Exchanger	<ol style="list-style-type: none"> 1) Loosen 1 fixing screws(CCW) on both sides. (Use +Screw Driver.) 2) Disassemble the pipes in both inlet and outlet with welding torch. 3) Detach the Heat Exchanger. <p>⚠ Before you disassemble the pipes and Condenser, be sure that there should be no refrigerant remained in the unit.</p>	
5	Ass'y Valve 4-Way & Ass'y Valve EEV	<ol style="list-style-type: none"> 1) Loosen 4 bolts(CCW) fixed to assemble Valve Service with Bracket Valve like the picture on the right side. (Use Monkey Spanner.) 2) Disassemble the pipes assembled the suction and discharge sides of the Compressor with welding torch. 	
6	Compressor	<ol style="list-style-type: none"> 1) Loosen the Nut(CCW) of Terminal Cover. (Use Monkey Spanner.) 2) Detach the Terminal Cover and detach the Connect Comp Wire from Compressor. 3) Disassemble the Felt Comp Sound. 4) Loosen the 3 bolts(CCW) at the bottom of Compressor like the picture on the right side. (Use Monkey Spanner.) 	

5. Disassembly WIFI

5-1 WIFI Case

No	Parts	Procedure	Remark
1	CASE	Separate Case-WIFI Top from Case-WIFI Button	
2	BUTTON	Separate Case-WIFI Top from Case-WIFI Button	
3	WIRE	Detach Assy Connector Wire from Case-WIFI Button *Caution When you separate the connector, pull pressing the locking button	
4	PBA	Separate PBA WIFI from Case-WIFI Button	

5-1 ASSY CONTROL IN

AR12HSSDPWKNEE
AR09HSSDPWKNEE

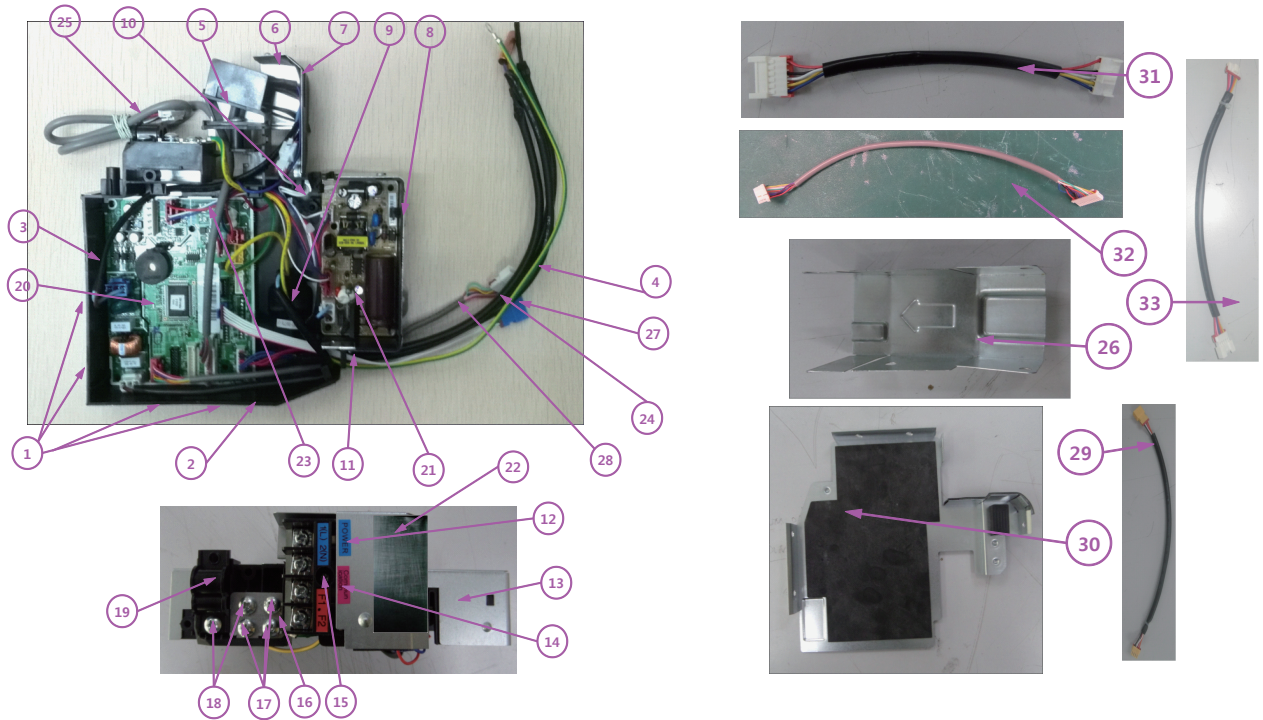

No	CODE	Description	Spec	Q' TY
	DB93-14734U	ASSY CONTROL IN		
1	DB63-03553C	Aluminum SHEET	10x10xT0.07, AL SHEET	4
2	DB61-05826A	CASE-CONTROL IN	CASE-CONTROL IN	1
3	DB93-14203A	POWER WIRE	T/B-main(power)	1
4	DB93-14245A	EARTH WIRE	EARTH WIRE	1
5	DB65-00326A	TERMINAL BLOCK	TERMINAL BLOCK	1
6	DB62-11656F	SEAL CUTT	PVC, BLACK, T1, W54	1
7	DB62-11680A	SEAL CONTROL	FLOCKED, BLACK, T1, W50, 54	1
8	DB68-02809A	ASSY-LABEL	ASSY-LABEL	1
9	DB93-06677A	ASSY CONNECTOR WIRE-DC	main-power (SMPS IN)	1
10	DB93-14207A	FUSE WIRE	power-main (12V 5V)	1
11	DB63-03553D	Aluminum SHEET	22x22xT0.07, AL SHEET	1
12	DB68-33293A	ASSY-LABEL	ASSY-LABEL	1
13	DB61-05807A	PLATE-CONTROL IN	F01	1
14	DB68-33292A	ASSY-LABEL	ASSY-LABEL	1
15	DB91-00309A	SCREW	M3, L25, ZPC (WHT) , SWRCH18A	1
16	DB61-05812A	PLATE	PLATE	1
17	6009-001001	SCREW	TH, M4, L10, ZPC (WHT) , SWRCH18A	3
18	6002-000231	SCREW	M4, L12, ZPC (WHT) , SWRCH18A	2
19	DB61-05871A	HOLDER-WIRE CLAMP	HOLDER-WIRE CLAMP	1
20	DB92-02873A	MAIN PBA	STD4	1
21	DB92-02861A	POWER PBA	STD11W	1
22	DB62-11793A	SEAL CASE-LEFT	SEAL CASE-LEFT	1
23	DB93-14208A	ASSY CONNECTOR WIRE-DC	power-main (310V 19V)	1
24	DB95-05163A	ASSY THERMISTOR IN	sensor room, 2evap	1
25	DB93-14221A	ASSY CONNECTOR WIRE-DC	FJM	1
26	DB61-05965A	PLATE CONTROL-UP	PLATE CONTROL-UP	1
27	DB93-14205A	ASSY CONNECTOR WIRE-DC	Step-main (Left)	1
28	DB93-14211A	ASSY CONNECTOR WIRE-DC	WIFI	1
29	DB93-04695A	ASSY CONNECTOR WIRE-DC	SPI	1
30	DB90-07859A	ASSY PLATE CONTROL	RIGHT	1
31	DB93-14724A	ASSY CONNECTOR WIRE-DC	BLDC	1
32	DB93-14209A	ASSY CONNECTOR WIRE-DC	DISPLAY MOTOR	1
33	DB93-14723A	ASSY CONNECTOR WIRE-DC	STEP MOTOR	1

5-1 ASSY CONTROL IN

AR09HSFSPWKNEE
AR12HSFSPWKNEE

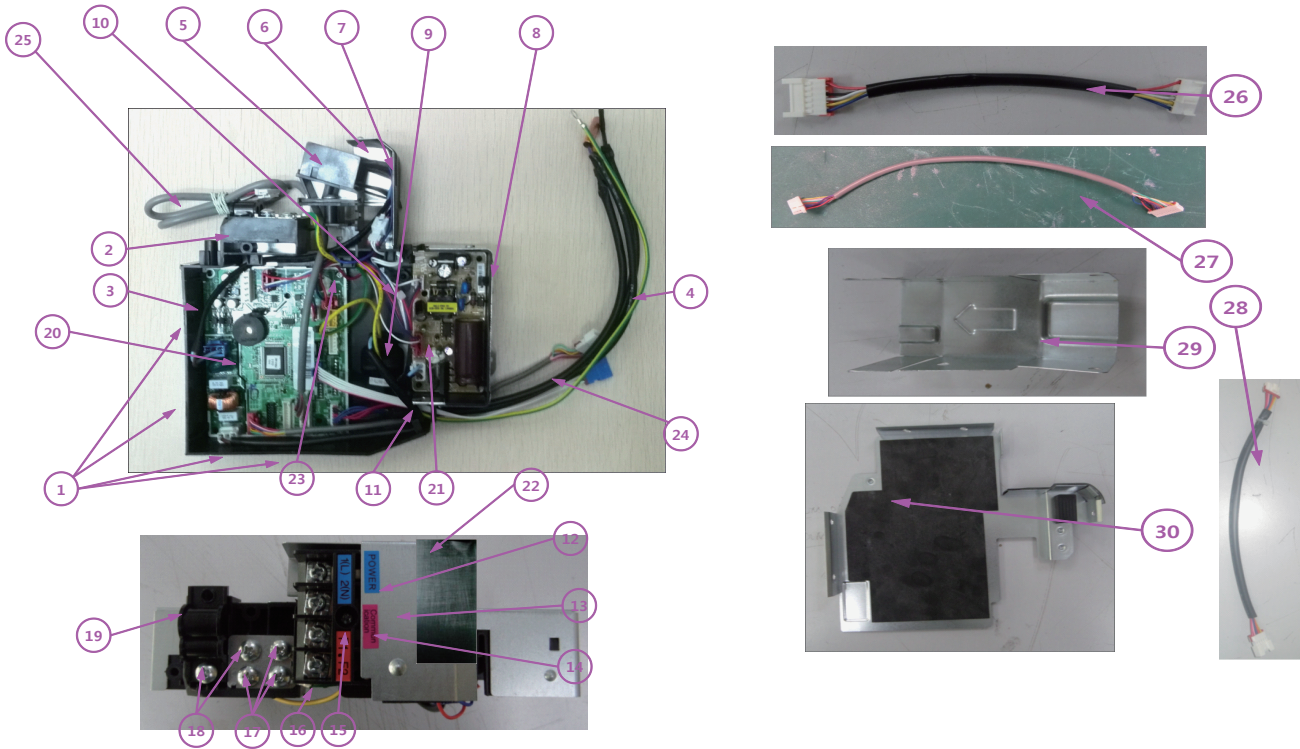

No	CODE	Description	Spec	Q' TY
	DB93-14734V	ASSY CONTROL IN		
1	DB63-03553C	ALUMINUM SHEET	10x10xT0.07, AL SHEET	4
2	DB61-05826A	CASE-CONTROL IN	CASE-CONTROL IN	1
3	DB93-14203A	POWER WIRE	T/B-main(power)	1
4	DB93-14245A	EARTH WIRE	EARTH WIRE	1
5	DB65-00326A	TERMINAL BLOCK	TERMINAL BLOCK	1
6	DB62-11656F	SEAL CUTT	PVC, BLACK, T1, W54	1
7	DB62-11680A	SEAL CONTROL	FLOCKED, BLACK, T1, W50, 54	1
8	DB68-02809A	ASSY-LABEL	ASSY-LABEL	1
9	DB93-06677A	COMMUNICATION WIRE	T/B-main(485)	1
10	DB93-14207A	FUSE WIRE	power-main(12V 5V)	1
11	DB63-03553D	ALUMINUM SHEET	22x22xT0.07, AL SHEET	1
12	DB68-33293A	ASSY-LABEL	ASSY-LABEL	1
13	DB61-05807A	PLATE-CONTROL IN	F01	1
14	DB68-33292A	ASSY-LABEL	ASSY-LABEL	1
15	DB91-00309A	SCREW	M3, L25, ZPC(WHT), SWRCH18A	1
16	DB61-05812A	PLATE	PLATE	1
17	6009-001001	SCREW	TH, M4, L10, ZPC(WHT), SWRCH18A	3
18	6002-000231	SCREW	M4, L12, ZPC(WHT), SWRCH18A	3
19	DB61-05871A	HOLDER-WIRE CLAMP	HOLDER-WIRE CLAMP	1
20	DB92-02873C	MAIN PBA	STD4	1
21	DB92-02861A	POWER PBA	STD11W	1
22	DB62-11793A	SEAL CASE-LEFT	SEAL CASE-LEFT	1
23	DB93-14208A	ASSY CONNECTOR WIRE-DC	power-main(310V 19V)	1
24	DB95-05163A	ASSY THERMISTOR IN	sensor 1room, 2evap	1
25	DB93-14221A	ASSY CONNECTOR WIRE-DC	FJM	1
26	DB93-14724A	ASSY CONNECTOR WIRE-DC	BLDC	1
27	DB93-14209A	ASSY CONNECTOR WIRE-DC	DISPLAY MOTOR	1
28	DB93-14723A	ASSY CONNECTOR WIRE-DC	STEP MOTOR	1
29	DB61-05965A	PLATE CONTROL-UP	PLATE CONTROL-UP	1
30	DB90-07859A	ASSY PLATE CONTROL	RIGHT	1

5-2 Assy Control Out (DB93-14201J)

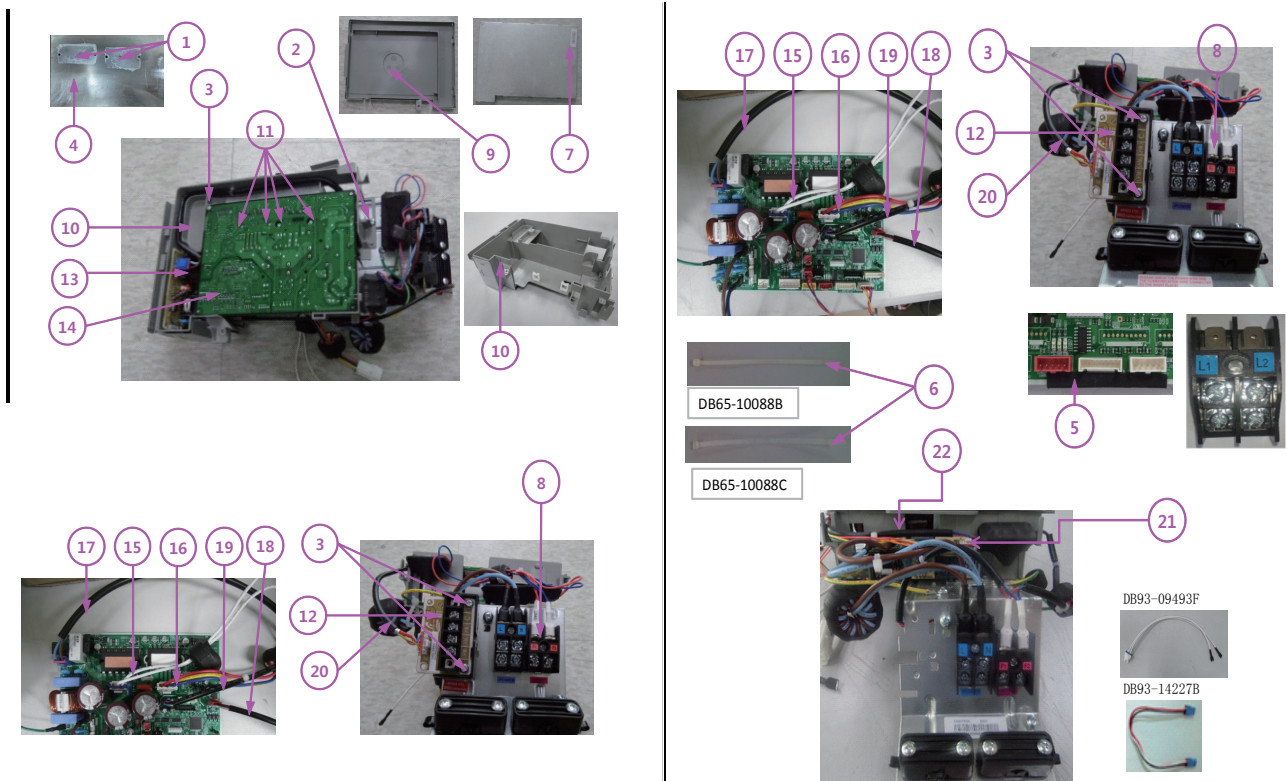

No	NAME	CODE	unit	REMARK
	ASSY CONTROL OUT	DB93-14201J		
1	GREASE-SILICON	0205-000178	0.002 KG	
2	SCREW-TAPPING	6002-000527	1 PC	
3	SCREW-TAPPING	6002-000536	1 PC	
4	HEAT SINK	DB62-11646A	1 PC	
5	SEAL CUTT	DB62-11656B	0 M	
6	CABLE TIE	DB65-10088B	0 PC	W3.6*L150
	CABLE TIE	DB65-10088C	1 PC	W4.8*L190
7	LABEL BAR CODE	DB68-02809A	1 PC	
8	ASSY CASE CONTROL OUT	DB90-06308L	0 PC	组件
	ASSY CASE CONTROL OUT	DB90-06308M	0 PC	
	ASSY CASE CONTROL OUT	DB90-06308N	0 PC	
	ASSY CASE CONTROL OUT	DB90-06308P	0 PC	
	ASSY CASE CONTROL OUT	DB90-06308Q	0 PC	
	ASSY CASE CONTROL OUT	DB90-06308R	0 PC	
	ASSY CASE CONTROL OUT	DB90-06308S	1 PC	
	ASSY CASE CONTROL OUT	DB90-06308T	0 PC	
	ASSY CASE CONTROL OUT	DB90-08330A	0 PC	
	ASSY CASE CONTROL OUT	DB90-08331A	0 PC	
	ASSY CASE CONTROL OUT	DB90-08332A	0 PC	
	ASSY CASE CONTROL OUT	DB90-08333A	0 PC	
9	ASSY COVER CONTROL-UP	DB90-07729A	1 PC	组件
10	ASSY CASE CONTROL	DB90-07833A	1 PC	
11	ASSY-SCREW MACHINE	DB91-00933A	4 PC	
12	ASSY PCB SUB	DB92-02836A	0 PC	
13	ASSY MODULE	DB92-02862A	1 PC	
14	ASSY PCB MAIN	DB92-02866A	1 PC	
		DB92-02866D	1 PC	
15	ASSY CONNECTOR WIRE	DB93-09493C	0 PC	
		DB93-09493F	1 PC	
16	ASSY CONNECTOR WIRE	DB93-09497E	1 PC	
17	ASSY CONNECTOR WIRE-POWER	DB93-14275A	1 PC	AC
18	ASSY CONNECTOR WIRE-DC SIGN	DB93-14276A	1 PC	
19	ASSY CONNECTOR WIRE-DC SIGN	DB93-14277A	0 PC	
		DB93-14277B	1 PC	
20	ASSY CONNECTOR WIRE-DC SIGN	DB93-14278A	0 PC	
21	ASSY CONNECTOR WIRE	DB93-15008A	1 PC	
22	ASSY PCB SUB-HEATER	DB93-13220A	1 PC	

6. Electrical Parts List

6-1 INDOOR MAIN PCB (DB92-02873C)

Parts Code	Design Loc	Parts Description	Quantity
0201-002081	-	ADHESIVE-SIL	0.8
0202-001463	SOLDER WIRE	SOLDER-WIRE	1.8
0202-001608	SOLDER-WIRE FLUX	SOLDER-WIRE FLUX	0.2
0204-004665	FLUX	FLUX	2
0502-000245	Q701	TR-POWER	1
1405-001239	VA71	VARISTOR	1
2301-002032	XC71	C-FILM, LEAD-PPF	1
2301-002032	XC72	C-FILM, LEAD-PPF	1
3002-001139	BZ61	BUZZER-PIEZO	1
3711-000024	CN76	HEADER-BOARD TO CABLE	1
3711-000177	CN21	HEADER-BOARD TO CABLE	1
3711-000203	CN75	HEADER-BOARD TO CABLE	1
3711-000296	CN72	HEADER-BOARD TO CABLE	1
3711-000941	CN81	HEADER-BOARD TO CABLE	1
3711-000998	CN77	CONNECTOR-HEADER	1
3711-000999	CN61	HEADER-BOARD TO CABLE	1
3711-002001	CN31	HEADER-BOARD TO CABLE	1
3711-003404	CN71	HEADER-BOARD TO CABLE	1
3711-003845	CN91	HEADER-BOARD TO CABLE	1
3711-004122	CN32	HEADER-BOARD TO CABLE	1
3711-004236	CN43	HEADER-BOARD TO CABLE	1
3711-005096	CN63	HEADER-BOARD TO CABLE	1
3711-005097	CN62	HEADER-BOARD TO CABLE	1
3711-005504	CN51	HEADER-BOARD TO CABLE	1
DB27-00096A	FT71	COIL CHOKE	1
DB67-00942A	VA71-1	CAP	1
DB68-02809A	LABEL BAR CODE	LABEL BAR CODE	1
DB94-04840A	-	ASSY PCB AUTO	1
0501-000362	Q801	TR-SMALL SIGNAL	1
1404-001194	PTC2	THERMISTOR-PTC	1
3601-001765	F701	FUSE-ETC	1
DB94-04841A	-	ASSY PCB SMD	1
0202-001459	SOLDER CREAM	SOLDER-CREAM	1
0402-001741	D701	DIODE-RECTIFIER	1
0406-001204	CD81	DIODE-TVS	1
0406-001204	CD82	DIODE-TVS	1
0406-001204	CD83	DIODE-TVS	1
0501-000465	Q702	TR-SMALL SIGNAL	1
0504-001080	Q601	TR-DIGITAL	1
0504-001080	Q802	TR-DIGITAL	1
0506-000175	IC05	TR-ARRAY	1
0506-000175	IC06	TR-ARRAY	1
0604-001002	PC03	PHOTO-COUPLER	1
0604-001002	PC04	PHOTO-COUPLER	1
0604-001002	PC05	PHOTO-COUPLER	1
0801-000393	IC08	IC-CMOS LOGIC	1
1006-001325	IC07	IC-BUS TRANSCEIVER	1
1202-000104	IC11	IC-VOLTAGE COMP.	1
1203-006245	IC03	IC-VOL. DETECTOR	1
1203-007526	IC02	IC-POSI. FIXED REG.	1
2007-000029	R850	R-CHIP	1
2007-000029	R851	R-CHIP	1
2007-000070	R717	R-CHIP	1
2007-000076	R601	R-CHIP	1
2007-000076	R602	R-CHIP	1
2007-000076	R716	R-CHIP	1
2007-000078	R703	R-CHIP	1
2007-000078	R706	R-CHIP	1
2007-000078	R805	R-CHIP	1
2007-000078	R815	R-CHIP	1
2007-000084	R707	R-CHIP	1
2007-000087	R708	R-CHIP	1
2007-000090	R701	R-CHIP	1
2007-000090	R704	R-CHIP	1
2007-000090	R705	R-CHIP	1
2007-000090	R723	R-CHIP	1
2007-000090	R801	R-CHIP	1
2007-000090	R802	R-CHIP	1

INDOOR MAIN PCB (DB92-02873C)

2007-000090	R803	R-CHIP	1
2007-000090	R804	R-CHIP	1
2007-000090	R816	R-CHIP	1
2007-000116	R825	R-CHIP	1
2007-000130	R715	R-CHIP	1
2007-000138	R508	R-CHIP	1
2007-000138	R515	R-CHIP	1
2007-000138	R516	R-CHIP	1
2007-000138	R517	R-CHIP	1
2007-000138	R518	R-CHIP	1
2007-000138	R519	R-CHIP	1
2007-000138	R520	R-CHIP	1
2007-000138	R539	R-CHIP	1
2007-000138	R542	R-CHIP	1
2007-000138	R809	R-CHIP	1
2007-000140	R538	R-CHIP	1
2007-000140	R545	R-CHIP	1
2007-000140	R806	R-CHIP	1
2007-000140	R901	R-CHIP	1
2007-000143	R511	R-CHIP	1
2007-000143	R512	R-CHIP	1
2007-000143	R513	R-CHIP	1
2007-000148	R502	R-CHIP	1
2007-000148	R503	R-CHIP	1
2007-000148	R504	R-CHIP	1
2007-000148	R505	R-CHIP	1
2007-000148	R506	R-CHIP	1
2007-000148	R507	R-CHIP	1
2007-000148	R510	R-CHIP	1
2007-000148	R521	R-CHIP	1
2007-000148	R522	R-CHIP	1
2007-000148	R523	R-CHIP	1
2007-000148	R524	R-CHIP	1
2007-000148	R525	R-CHIP	1
2007-000148	R526	R-CHIP	1
2007-000148	R527	R-CHIP	1
2007-000148	R528	R-CHIP	1
2007-000148	R529	R-CHIP	1
2007-000148	R530	R-CHIP	1
2007-000148	R531	R-CHIP	1
2007-000148	R532	R-CHIP	1
2007-000148	R533	R-CHIP	1
2007-000148	R534	R-CHIP	1
2007-000148	R543	R-CHIP	1
2007-000148	R544	R-CHIP	1
2007-000148	R807	R-CHIP	1
2007-000148	R808	R-CHIP	1
2007-000148	R810	R-CHIP	1
2007-000148	R824	R-CHIP	1
2007-000148	R903	R-CHIP	1
2007-000148	R904	R-CHIP	1
2007-000157	R902	R-CHIP	1
2007-000162	R820	R-CHIP	1
2007-000162	R821	R-CHIP	1
2007-000171	R831	R-CHIP	1
2007-000171	R833	R-CHIP	1
2007-000171	R835	R-CHIP	1
2007-000171	R837	R-CHIP	1
2007-000171	R839	R-CHIP	1
2007-000171	R843	R-CHIP	1
2007-000303	R702	R-CHIP	1
2007-000385	R115	R-CHIP	1
2007-000455	R712	R-CHIP	1
2007-000475	R709	R-CHIP	1
2007-000583	R714	R-CHIP	1
2007-000924	R112	R-CHIP	1
2007-000924	R113	R-CHIP	1
2007-000924	R114	R-CHIP	1
2007-000939	R711	R-CHIP	1
2007-000979	R713	R-CHIP	1

INDOOR MAIN PCB (DB92-02873C)

2007-001313	R404	R-CHIP	1
2007-001313	R405	R-CHIP	1
2007-001313	R406	R-CHIP	1
2007-001313	R410	R-CHIP	1
2007-001313	R811	R-CHIP	1
2007-001433	R618	R-CHIP	1
2007-007313	R401	R-CHIP	1
2007-007313	R402	R-CHIP	1
2007-007313	R403	R-CHIP	1
2007-009922	R301	R-CHIP	1
2007-009922	R302	R-CHIP	1
2007-009922	R303	R-CHIP	1
2203-000257	C705	C-CER, CHIP	1
2203-000257	C801	C-CER, CHIP	1
2203-000438	C508	C-CER, CHIP	1
2203-000438	C516	C-CER, CHIP	1
2203-000438	C520	C-CER, CHIP	1
2203-000438	C901	C-CER, CHIP	1
2203-000440	C711	C-CER, CHIP	1
2203-000440	C715	C-CER, CHIP	1
2203-001071	C519	C-CER, CHIP	1
2203-005249	C401	C-CER, CHIP	1
2203-005249	C402	C-CER, CHIP	1
2203-005249	C403	C-CER, CHIP	1
2203-005249	C511	C-CER, CHIP	1
2203-005249	C513	C-CER, CHIP	1
2203-005249	C514	C-CER, CHIP	1
2203-005249	C517	C-CER, CHIP	1
2203-005249	C522	C-CER, CHIP	1
2203-005249	C529	C-CER, CHIP	1
2203-005249	C530	C-CER, CHIP	1
2203-005249	C531	C-CER, CHIP	1
2203-005249	C533	C-CER, CHIP	1
2203-005249	C702	C-CER, CHIP	1
2203-005249	C704	C-CER, CHIP	1
2203-005249	C710	C-CER, CHIP	1
2203-005249	C712	C-CER, CHIP	1
2203-005249	C713	C-CER, CHIP	1
2203-005249	C802	C-CER, CHIP	1
2203-005249	C803	C-CER, CHIP	1
2203-005249	C805	C-CER, CHIP	1
2203-005249	C806	C-CER, CHIP	1
2203-005249	C807	C-CER, CHIP	1
2203-005249	C809	C-CER, CHIP	1
2203-006496	C707	C-CER, CHIP	1
2203-006960	C708	C-CER, CHIP	1
2203-007486	C509	C-CER, CHIP	1
2203-007486	C512	C-CER, CHIP	1
2203-007486	C515	C-CER, CHIP	1
2203-007486	C518	C-CER, CHIP	1
2203-007486	C521	C-CER, CHIP	1
2203-007486	C523	C-CER, CHIP	1
2203-007486	C526	C-CER, CHIP	1
2203-007486	C528	C-CER, CHIP	1
2203-007486	C551	C-CER, CHIP	1
2203-007486	C552	C-CER, CHIP	1
2203-007486	C804	C-CER, CHIP	1
2203-007486	C808	C-CER, CHIP	1
2402-000120	C706	C-AL, SMD	1
2402-001145	C701	C-AL, SMD	1
2402-001145	C703	C-AL, SMD	1
2802-001211	X501	RESONATOR-CERAMIC	1
DB41-01221A	PCB MAIN	PCB MAIN	1
DB91-01550B	-	ASSY MICOM	1
0903-001864	-	IC-MICROCONTROLLER	1
DB98-31449A	ASSY-LABEL MICOM	ASSY-LABEL MICOM	1

6-2 OUTDOOR MAIN PBA(DB92-02866D)

Parts Code	Design Loc	Quantity	Spec.
0202-001338	SOLDER-BAR	0.47	Lead-free Solder BAR, W20L350H8, 99.3Sn/0.7Cu/0.01P
0202-001463	SOLDER-WIRE	4.27	LFC2-W3.0, -, D3, 99.79Sn/0.2Cu/0.01P, -
0204-004665	FLUX	0.43	KSP-70M-S, 14%, FLUX
0204-005794	SOLVENT	1	S-1000, (CH3)2CHOH, 100%, 0.79
1404-001498	PTC020	1	40ohm, 25%, 290Vac, 7A, TR
1405-000154	VA002	1	560V, 460Vdc, 4500A, 17.5x7.5mm, BK, 920V, 600pF
1405-000154	VA003	1	560V, 460Vdc, 4500A, 17.5x7.5mm, BK, 920V, 600pF
1405-001239	VA001	1	680V, 560Vdc, 6000A, 17x7.3mm, BK, 1120V, 350pF
1405-001239	VA401	1	680V, 560Vdc, 6000A, 17x7.3mm, BK, 1120V, 350pF
2201-000540	C425	1	4.7nF, 20%, 2000V, Y5U, 12x5mm, 10mm
2201-002002	C004	1	4.7nF, 20%, 400V, Y5U, 16x6mm, 10mm
2201-002002	C005	1	4.7nF, 20%, 400V, Y5U, 16x6mm, 10mm
2201-002002	C012	1	4.7nF, 20%, 400V, Y5U, 16x6mm, 10mm
2201-002002	C013	1	4.7nF, 20%, 400V, Y5U, 16x6mm, 10mm
2301-001285	C001	1	680nF, 10%, 275V, BK, 31x11x21mm
2301-001285	C006	1	680nF, 10%, 275V, BK, 31x11x21mm
2306-000123	C412	1	100nF, 5%, 630V, BK, 26x16.5x8.5mm
2401-004874	CE101	1	330uF, 20%, 400V, BK, 25.4*50, 10mm
2401-004874	CE102	1	330uF, 20%, 400V, BK, 25.4*50, 10mm
2401-004874	CE103	1	330uF, 20%, 400V, BK, 25.4*50, 10mm
3501-001154	RY022	1	12V, 200mW, 3000mA, 1FormA, 10ms, 10ms
3501-001154	RY030	1	12V, 200mW, 3000mA, 1FormA, 10ms, 10ms
3501-001279	RY021	1	12V, 400mW, 16000mA, 1FormA, 15ms, 5ms
3711-000177	CN301	1	1WALL, 2P, 1R, 3.96MM, STRAIGHT, SN, RED
3711-000203	CN030	1	1WALL, 2P/3P, 1R, 7.92mm, STRAIGHT, SN, WHT, 8.5x11.8 2x3.2mm
3711-000296	CN901	1	1WALL, 6P, 1R, 3.96MM, STRAIGHT, SN, WHT
3711-000760	CN551	1	BOX, 20P, 2R, 2MM, ANGLE, SN, BLK
3711-002001	CN201	1	BOX, 20P, 2R, 2MM, STRAIGHT, SN, BLK
3711-003404	CN150	1	1WALL, 2P, 1R, 7.92mm, STRAIGHT, SN, BLU
3711-003843	CN251	1	BOX, 8P, 1R, 2mm, STRAIGHT, SN, WHT
3711-007656	CN402	1	BOX, 3, 1R, 6mm, STRAIGHT, WHT
3711-007659	CN401	1	BOX, 2, 1R, 7.92mm, STRAIGHT, WHT
3711-007817	CN501	1	3WALL, 7P, 1R, 2mm, STRAIGHT, SN, WHT
3712-001047	CN003	1	TAB, MALE, N, 0.5/4.75mm
3712-001139	CN001	1	TAB, MALE, 6.35x0.8mm
3712-001139	CN002	1	TAB, MALE, 6.35x0.8mm
4719-002483	PFC050	1	Smart Power Module, FPAB20BH60B, 600V, 20A, 89W, 20kHz, PFCM
4719-002484	IPM400	1	Smart Power
DB27-00097A	FT001	1	CC-35-15SS, SI, 3.5mH, +50~-30%, 15mohm Max, 15A, - 25~+115
DB61-05296A	SUPPORT-IC	1	AFX-HD233A, PA66, FR50, BLACK
DB61-05916A	SUPPORT-PCB	1	XS01_V2MD, PA+GF40, BLACK
DB68-02809A	-	1	ART, 45, 15, E-PASS
DB94-04846A	-	1	OUTDOOR, COLD AREA, A3050, 197*142, NEW PF#2, DB92- 02866D
0504-001044	Q151	1	KRA226M, PNP, 400MW, 2.2K/10K, TO-92M, TP
2201-002427	C901	1	2.2nF, K(10%), 2000V, Y5P, 12.5x5mm, 7.5mm
2401-000303	CE162	1	100uF, 20%, 25V, WT, TP, 6.3x11mm, 5mm
2401-000303	CE163	1	100uF, 20%, 25V, WT, TP, 6.3x11mm, 5mm
2401-001838	CE151	1	470uF, 20%, 25V, WT, TP, 10x16, 5mm
2401-002438	CE902	1	47uF, 20%, 50V, WT, TP, 6.3x11, 5mm
2401-003224	CE152	1	470uF, 20%, 16V, WT, TP, 8x11.5, 5mm
2401-003585	CE901	1	220uF, 20%, 35V, WT, TP, 8x11.5mm, 5
3601-001538	F001	1	250V, 15A, TIME-LAG, CERAMIC, 6.35x31.8mm
3711-000015	CN203	1	BOX, 2P, 1R, 2.5mm, STRAIGHT, SN, WHT, 5.8X7.4X7.0mm
3711-000024	CN202	1	BOX, 3P, 1R, 2.5MM, STRAIGHT, SN, WHT
3711-000879	CN152	1	BOX, 3P, 1R, 2.5mm, STRAIGHT, SN, BLU
3711-000880	CN151	1	BOX, 3P, 1R, 2.5MM, STRAIGHT, SN, RED
3711-000998	CN701	1	BOX, 5P, 1R, 2.5MM, STRAIGHT, SN, RED

OUTDOOR MAIN PBA(DB92-02866D)

3711-000999	CN204	1	BOX, 5P, 1R, 2. 5mm, STRAIGHT, SN, WHT
3711-004182	CN206	1	BOX, 10P, 1R, 2mm, STRAIGHT, SN, WHT
3711-005096	CN205	1	BOX, 5P, 1R, 2MM, STRAIGHT, SN, BLK
4715-001093	DSA001	1	3600V, 20%, 2000A, -, AXIAL
DB94-04847A	-	1	OUTDOOR, COLD AREA, A3050, 197*142, NEW PF#2, DB92-02866D
0202-001459	SOLDER-CREAM	1	S3X58-M405, D20~38um, 96. 5Sn/3Ag/0. 5Cu, FLUX 5%
0401-001099	D020	1	1N4148WS, 75V, 150mA, SOD-323, TP
0401-001099	D021	1	1N4148WS, 75V, 150mA, SOD-323, TP
0401-001099	D030	1	1N4148WS, 75V, 150mA, SOD-323, TP
0401-001099	D152	1	1N4148WS, 75V, 150mA, SOD-323, TP
0401-001099	D153	1	1N4148WS, 75V, 150mA, SOD-323, TP
0401-001099	D454	1	1N4148WS, 75V, 150mA, SOD-323, TP
0401-001099	D500	1	1N4148WS, 75V, 150mA, SOD-323, TP
0401-001099	D501	1	1N4148WS, 75V, 150mA, SOD-323, TP
0401-001099	D502	1	1N4148WS, 75V, 150mA, SOD-323, TP
0401-001099	D503	1	1N4148WS, 75V, 150mA, SOD-323, TP
0401-001099	D504	1	1N4148WS, 75V, 150mA, SOD-323, TP
0401-001099	D505	1	1N4148WS, 75V, 150mA, SOD-323, TP
0401-001099	D507	1	1N4148WS, 75V, 150mA, SOD-323, TP
0401-001099	D508	1	1N4148WS, 75V, 150mA, SOD-323, TP
0401-001099	D904	1	1N4148WS, 75V, 150mA, SOD-323, TP
0401-001099	D905	1	1N4148WS, 75V, 150mA, SOD-323, TP
0402-001795	D903	1	US1M, 1000V, 1A, SMA, TP
0403-001499	ZD401	1	MMSZ5252B, 22. 8/25. 2V, 500mW, SOD-123, TP
0403-001499	ZD420	1	MMSZ5252B, 22. 8/25. 2V, 500mW, SOD-123, TP
0404-001020	D491	1	BAT54C, 30V, 200mA, SOT-23, TP
0404-001020	D492	1	BAT54C, 30V, 200mA, SOT-23, TP
0406-001204	TD301	1	SMBJ5. 0CA, 6. 4/-/7. 25V, 600W, SMB
0406-001204	TD302	1	SMBJ5. 0CA, 6. 4/-/7. 25V, 600W, SMB
0406-001204	TD303	1	SMBJ5. 0CA, 6. 4/-/7. 25V, 600W, SMB
0501-000465	Q551	1	MMBT3904, NPN, 350mW, SOT-23, TP, 30-300
0504-001008	Q351	1	RN2427, PNP, 200mW, 2. 2K/10Kohm, SOT-23, TP
0504-001008	Q352	1	RN2427, PNP, 200mW, 2. 2K/10Kohm, SOT-23, TP
0504-001008	Q901	1	RN2427, PNP, 200mW, 2. 2K/10Kohm, SOT-23, TP
0504-001008	Q903	1	RN2427, PNP, 200mW, 2. 2K/10Kohm, SOT-23, TP
0504-001080	Q902	1	KRC246S, NPN, 200mW, 2. 2K/10Kohm, SOT-23, TP
0506-000175	IC061	1	2003, NPN, 7, 1000mW, SOP-16, ST, 1000
0506-000175	IC701	1	2003, NPN, 7, 1000mW, SOP-16, ST, 1000
0506-000175	IC702	1	2003, NPN, 7, 1000mW, SOP-16, ST, 1000
0601-002423	LED801	1	SMD (REVERSE), RED, 3. 2x1. 6mm, 639nm, 3. 2x1. 6x1. 1mm
0601-002955	LED803	1	SMD (REVERSE), YEL, 1. 6x1. 5mm, 588nm, 3. 2x1. 6x1. 1mm
0601-002956	LED551	1	SMD (REVERSE), GRN, 1. 6x1. 5mm, 3. 2x1. 6x1. 1mm
0601-002956	LED802	1	SMD (REVERSE), GRN, 1. 6x1. 5mm, 3. 2x1. 6x1. 1mm
0604-001172	PC151	1	TR, 150-300, 200mW, SOP, TP
0604-001172	PC351	1	TR, 150-300, 200mW, SOP, TP
0604-001172	PC352	1	TR, 150-300, 200mW, SOP, TP
0801-000393	IC302	1	74HC86, OR GATE, SOP, 14P, 150MIL, QUAD, ST, -2. 0/6. 0V, 0. 26V, -40to+85C, 180mW, 4. 2V, 1uA,
1006-001325	IC301	1	ISL81487LIBZ, SO, 8P, 4. 9x3. 8mm, SINGLE, ST, PLASTIC, 5V, -40to+85C, 520mW, 1. 1. 1. 5/5. 0V
1201-002946	IC451	1	TSSOP, TR, 14P, 5x4. 4x1. 2mm, 100, 5. 5V, -40to+85C, 63dB, 1. 1nA, 1nA, 1. 7mV
1203-002835	IC154	1	7805, 3P, 6. 6x6. 1mm, PLASTIC, 4. 8V/5. 2V, 1. 3W, -40to+85. 1A, TP
1203-002986	IC155	1	7812, 3P, 6. 6x6. 1mm, PLASTIC, 11. 5/12. 5V, 1. 3, 150C, 1A, TP
1203-004967	IC502	1	KIA7042AT, TSM, 3P, 2. 9x1. 6mm, PLASTIC, 4. 2V, 350mW, -30to+75C, 20mA, -, -
2007-000043	R424	1	1Kohm, 1%, 1/10W, TP, 1608
2007-000070	R309	1	0ohm, 5%, 1/10W, TP, 1608
2007-000074	R152	1	100ohm, 5%, 1/10W, TP, 1608
2007-000074	R210	1	100ohm, 5%, 1/10W, TP, 1608
2007-000074	R213	1	100ohm, 5%, 1/10W, TP, 1608
2007-000074	R233	1	100ohm, 5%, 1/10W, TP, 1608
2007-000074	R234	1	100ohm, 5%, 1/10W, TP, 1608
2007-000074	R401	1	100ohm, 5%, 1/10W, TP, 1608
2007-000074	R402	1	100ohm, 5%, 1/10W, TP, 1608
2007-000074	R403	1	100ohm, 5%, 1/10W, TP, 1608
2007-000074	R404	1	100ohm, 5%, 1/10W, TP, 1608
2007-000074	R405	1	100ohm, 5%, 1/10W, TP, 1608
2007-000074	R406	1	100ohm, 5%, 1/10W, TP, 1608

OUTDOOR MAIN PBA(DB92-02866D)

2007-000074	R407	1	100ohm, 5%, 1/10W, TP, 1608
2007-000074	R420	1	100ohm, 5%, 1/10W, TP, 1608
2007-000074	R422	1	100ohm, 5%, 1/10W, TP, 1608
2007-000074	R516	1	100ohm, 5%, 1/10W, TP, 1608
2007-000074	R519	1	100ohm, 5%, 1/10W, TP, 1608
2007-000074	R562	1	100ohm, 5%, 1/10W, TP, 1608
2007-000076	R153	1	330ohm, 5%, 1/10W, TP, 1608
2007-000076	R255	1	330ohm, 5%, 1/10W, TP, 1608
2007-000076	R256	1	330ohm, 5%, 1/10W, TP, 1608
2007-000076	R257	1	330ohm, 5%, 1/10W, TP, 1608
2007-000076	R258	1	330ohm, 5%, 1/10W, TP, 1608
2007-000076	R352	1	330ohm, 5%, 1/10W, TP, 1608
2007-000076	R353	1	330ohm, 5%, 1/10W, TP, 1608
2007-000076	R512	1	330ohm, 5%, 1/10W, TP, 1608
2007-000076	R567	1	330ohm, 5%, 1/10W, TP, 1608
2007-000076	R904	1	330ohm, 5%, 1/10W, TP, 1608
2007-000078	R303	1	1Kohm, 5%, 1/10W, TP, 1608
2007-000078	R307	1	1Kohm, 5%, 1/10W, TP, 1608
2007-000078	R308	1	1Kohm, 5%, 1/10W, TP, 1608
2007-000078	R351	1	1Kohm, 5%, 1/10W, TP, 1608
2007-000078	R354	1	1Kohm, 5%, 1/10W, TP, 1608
2007-000078	R503	1	1Kohm, 5%, 1/10W, TP, 1608
2007-000078	R504	1	1Kohm, 5%, 1/10W, TP, 1608
2007-000078	R505	1	1Kohm, 5%, 1/10W, TP, 1608
2007-000078	R508	1	1Kohm, 5%, 1/10W, TP, 1608
2007-000078	R509	1	1Kohm, 5%, 1/10W, TP, 1608
2007-000078	R515	1	1Kohm, 5%, 1/10W, TP, 1608
2007-000078	R529	1	1Kohm, 5%, 1/10W, TP, 1608
2007-000078	R530	1	1Kohm, 5%, 1/10W, TP, 1608
2007-000078	R556	1	1Kohm, 5%, 1/10W, TP, 1608
2007-000078	R557	1	1Kohm, 5%, 1/10W, TP, 1608
2007-000078	R558	1	1Kohm, 5%, 1/10W, TP, 1608
2007-000078	R560	1	1Kohm, 5%, 1/10W, TP, 1608
2007-000078	R563	1	1Kohm, 5%, 1/10W, TP, 1608
2007-000080	R522	1	2Kohm, 5%, 1/10W, TP, 1608
2007-000082	R421	1	3.3Kohm, 5%, 1/10W, TP, 1608
2007-000084	R211	1	4.7Kohm, 5%, 1/10W, TP, 1608
2007-000084	R212	1	4.7Kohm, 5%, 1/10W, TP, 1608
2007-000084	R214	1	4.7Kohm, 5%, 1/10W, TP, 1608
2007-000084	R215	1	4.7Kohm, 5%, 1/10W, TP, 1608
2007-000084	R216	1	4.7Kohm, 5%, 1/10W, TP, 1608
2007-000084	R217	1	4.7Kohm, 5%, 1/10W, TP, 1608
2007-000084	R218	1	4.7Kohm, 5%, 1/10W, TP, 1608
2007-000084	R219	1	4.7Kohm, 5%, 1/10W, TP, 1608
2007-000084	R220	1	4.7Kohm, 5%, 1/10W, TP, 1608
2007-000084	R408	1	4.7Kohm, 5%, 1/10W, TP, 1608
2007-000084	R501	1	4.7Kohm, 5%, 1/10W, TP, 1608
2007-000084	R506	1	4.7Kohm, 5%, 1/10W, TP, 1608
2007-000084	R507	1	4.7Kohm, 5%, 1/10W, TP, 1608
2007-000084	R510	1	4.7Kohm, 5%, 1/10W, TP, 1608
2007-000084	R511	1	4.7Kohm, 5%, 1/10W, TP, 1608
2007-000084	R517	1	4.7Kohm, 5%, 1/10W, TP, 1608
2007-000084	R518	1	4.7Kohm, 5%, 1/10W, TP, 1608
2007-000084	R520	1	4.7Kohm, 5%, 1/10W, TP, 1608
2007-000084	R521	1	4.7Kohm, 5%, 1/10W, TP, 1608
2007-000084	R523	1	4.7Kohm, 5%, 1/10W, TP, 1608
2007-000084	R524	1	4.7Kohm, 5%, 1/10W, TP, 1608
2007-000084	R525	1	4.7Kohm, 5%, 1/10W, TP, 1608
2007-000084	R526	1	4.7Kohm, 5%, 1/10W, TP, 1608
2007-000084	R527	1	4.7Kohm, 5%, 1/10W, TP, 1608
2007-000084	R534	1	4.7Kohm, 5%, 1/10W, TP, 1608
2007-000084	R535	1	4.7Kohm, 5%, 1/10W, TP, 1608
2007-000084	R536	1	4.7Kohm, 5%, 1/10W, TP, 1608
2007-000084	R903	1	4.7Kohm, 5%, 1/10W, TP, 1608
2007-000090	R301	1	10Kohm, 5%, 1/10W, TP, 1608

OUTDOOR MAIN PBA(DB92-02866D)

2007-000090	R302	1	10Kohm, 5%, 1/10W, TP, 1608
2007-000090	R304	1	10Kohm, 5%, 1/10W, TP, 1608
2007-000090	R305	1	10Kohm, 5%, 1/10W, TP, 1608
2007-000090	R528	1	10Kohm, 5%, 1/10W, TP, 1608
2007-000090	R532	1	10Kohm, 5%, 1/10W, TP, 1608
2007-000090	R533	1	10Kohm, 5%, 1/10W, TP, 1608
2007-000090	R551	1	10Kohm, 5%, 1/10W, TP, 1608
2007-000090	R552	1	10Kohm, 5%, 1/10W, TP, 1608
2007-000090	R553	1	10Kohm, 5%, 1/10W, TP, 1608
2007-000090	R554	1	10Kohm, 5%, 1/10W, TP, 1608
2007-000090	R555	1	10Kohm, 5%, 1/10W, TP, 1608
2007-000090	R559	1	10Kohm, 5%, 1/10W, TP, 1608
2007-000090	R565	1	10Kohm, 5%, 1/10W, TP, 1608
2007-000109	R531	1	1Mohm, 5%, 1/10W, TP, 1608
2007-000116	R306	1	120ohm, 5%, 1/10W, TP, 1608
2007-000124	R564	1	2.2Kohm, 5%, 1/10W, TP, 1608
2007-000140	R202	1	1Kohm, 5%, 1/16W, TP, 1005
2007-000140	R205	1	1Kohm, 5%, 1/16W, TP, 1005
2007-000143	R207	1	4.7Kohm, 5%, 1/16W, TP, 1005
2007-000143	R221	1	4.7Kohm, 5%, 1/16W, TP, 1005
2007-000143	R222	1	4.7Kohm, 5%, 1/16W, TP, 1005
2007-000143	R223	1	4.7Kohm, 5%, 1/16W, TP, 1005
2007-000143	R224	1	4.7Kohm, 5%, 1/16W, TP, 1005
2007-000143	R225	1	4.7Kohm, 5%, 1/16W, TP, 1005
2007-000143	R226	1	4.7Kohm, 5%, 1/16W, TP, 1005
2007-000143	R227	1	4.7Kohm, 5%, 1/16W, TP, 1005
2007-000143	R228	1	4.7Kohm, 5%, 1/16W, TP, 1005
2007-000143	R229	1	4.7Kohm, 5%, 1/16W, TP, 1005
2007-000143	R230	1	4.7Kohm, 5%, 1/16W, TP, 1005
2007-000143	R231	1	4.7Kohm, 5%, 1/16W, TP, 1005
2007-000143	R232	1	4.7Kohm, 5%, 1/16W, TP, 1005
2007-000148	R203	1	10Kohm, 5%, 1/16W, TP, 1005
2007-000148	R204	1	10Kohm, 5%, 1/16W, TP, 1005
2007-000148	R206	1	10Kohm, 5%, 1/16W, TP, 1005
2007-000170	R201	1	1Mohm, 5%, 1/16W, TP, 1005
2007-000239	R491	1	1.5Kohm, 1%, 1/10W, TP, 1608
2007-000256	R455	1	1.6Kohm, 1%, 1/10W, TP, 1608
2007-000256	R457	1	1.6Kohm, 1%, 1/10W, TP, 1608
2007-000256	R468	1	1.6Kohm, 1%, 1/10W, TP, 1608
2007-000300	R901	1	10Kohm, 5%, 1/8W, TP, 2012
2007-000385	R101	1	14.3Kohm, 1%, 1/4W, TP, 3216
2007-000385	R105	1	14.3Kohm, 1%, 1/4W, TP, 3216
2007-000455	R251	1	18Kohm, 1%, 1/10W, TP, 1608
2007-000455	R253	1	18Kohm, 1%, 1/10W, TP, 1608
2007-000491	R561	1	2.2Kohm, 1%, 1/10W, TP, 1608
2007-000536	R492	1	200ohm, 1%, 1/10W, TP, 1608
2007-000537	R154	1	200ohm, 1%, 1/4W, TP, 3216
2007-000537	R155	1	200ohm, 1%, 1/4W, TP, 3216
2007-000537	R156	1	200ohm, 1%, 1/4W, TP, 3216
2007-000537	R157	1	200ohm, 1%, 1/4W, TP, 3216
2007-000537	R158	1	200ohm, 1%, 1/4W, TP, 3216
2007-000614	R252	1	24Kohm, 1%, 1/10W, TP, 1608
2007-000614	R254	1	24Kohm, 1%, 1/10W, TP, 1608
2007-000614	R469	1	24Kohm, 1%, 1/10W, TP, 1608
2007-000614	R470	1	24Kohm, 1%, 1/10W, TP, 1608
2007-000614	R471	1	24Kohm, 1%, 1/10W, TP, 1608
2007-000614	R472	1	24Kohm, 1%, 1/10W, TP, 1608
2007-000614	R473	1	24Kohm, 1%, 1/10W, TP, 1608
2007-000614	R474	1	24Kohm, 1%, 1/10W, TP, 1608
2007-000651	R475	1	27Kohm, 1%, 1/10W, TP, 1608
2007-000683	R454	1	3.3Kohm, 1%, 1/10W, TP, 1608
2007-000683	R459	1	3.3Kohm, 1%, 1/10W, TP, 1608
2007-000683	R466	1	3.3Kohm, 1%, 1/10W, TP, 1608
2007-000763	R476	1	330ohm, 1%, 1/10W, TP, 1608
2007-000763	R477	1	330ohm, 1%, 1/10W, TP, 1608

OUTDOOR MAIN PBA(DB92-02866D)

2007-000872	R801	1	4.7Kohm, 5%, 1/8W, TP, 2012
2007-000872	R802	1	4.7Kohm, 5%, 1/8W, TP, 2012
2007-000872	R803	1	4.7Kohm, 5%, 1/8W, TP, 2012
2007-000924	R102	1	470Kohm, 1%, 1/4W, TP, 3216
2007-000924	R103	1	470Kohm, 1%, 1/4W, TP, 3216
2007-000924	R104	1	470Kohm, 1%, 1/4W, TP, 3216
2007-000924	R106	1	470Kohm, 1%, 1/4W, TP, 3216
2007-000924	R107	1	470Kohm, 1%, 1/4W, TP, 3216
2007-000924	R108	1	470Kohm, 1%, 1/4W, TP, 3216
2007-000979	R478	1	5.6Kohm, 1%, 1/10W, TP, 1608
2007-001071	R902	1	6.8Kohm, 5%, 1/8W, TP, 2012
2007-001175	R409	1	8.2Kohm, 1%, 1/10W, TP, 1608
2007-001175	R423	1	8.2Kohm, 1%, 1/10W, TP, 1608
2007-001175	R427	1	8.2Kohm, 1%, 1/10W, TP, 1608
2007-010245	R410	1	0.01ohm, 1%, 2W, TP, 6432
2007-010245	R411	1	0.01ohm, 1%, 2W, TP, 6432
2007-010245	R412	1	0.01ohm, 1%, 2W, TP, 6432
2007-010245	R425	1	0.01ohm, 1%, 2W, TP, 6432
2007-010245	R426	1	0.01ohm, 1%, 2W, TP, 6432
2203-000236	C421	1	0.1nF, 5%, 50V, COG, TP, 1608
2203-000257	C222	1	10nF, 10%, 50V, X7R, TP, 1608
2203-000257	C223	1	10nF, 10%, 50V, X7R, TP, 1608
2203-000257	C224	1	10nF, 10%, 50V, X7R, TP, 1608
2203-000257	C225	1	10nF, 10%, 50V, X7R, TP, 1608
2203-000257	C301	1	10nF, 10%, 50V, X7R, TP, 1608
2203-000257	C351	1	10nF, 10%, 50V, X7R, TP, 1608
2203-000257	C352	1	10nF, 10%, 50V, X7R, TP, 1608
2203-000257	C422	1	10nF, 10%, 50V, X7R, TP, 1608
2203-000257	C423	1	10nF, 10%, 50V, X7R, TP, 1608
2203-000440	C404	1	1nF, 10%, 50V, X7R, TP, 1608
2203-000440	C405	1	1nF, 10%, 50V, X7R, TP, 1608
2203-000440	C406	1	1nF, 10%, 50V, X7R, TP, 1608
2203-000440	C408	1	1nF, 10%, 50V, X7R, TP, 1608
2203-000440	C409	1	1nF, 10%, 50V, X7R, TP, 1608
2203-000440	C410	1	1nF, 10%, 50V, X7R, TP, 1608
2203-000440	C411	1	1nF, 10%, 50V, X7R, TP, 1608
2203-000440	C501	1	1nF, 10%, 50V, X7R, TP, 1608
2203-000440	C504	1	1nF, 10%, 50V, X7R, TP, 1608
2203-000440	C505	1	1nF, 10%, 50V, X7R, TP, 1608
2203-000440	C506	1	1nF, 10%, 50V, X7R, TP, 1608
2203-000440	C507	1	1nF, 10%, 50V, X7R, TP, 1608
2203-000440	C508	1	1nF, 10%, 50V, X7R, TP, 1608
2203-000440	C510	1	1nF, 10%, 50V, X7R, TP, 1608
2203-000440	C512	1	1nF, 10%, 50V, X7R, TP, 1608
2203-000440	C523	1	1nF, 10%, 50V, X7R, TP, 1608
2203-000440	C904	1	1nF, 10%, 50V, X7R, TP, 1608
2203-000783	C455	1	0.33nF, 5%, 50V, COG, TP, 1608
2203-000783	C458	1	0.33nF, 5%, 50V, COG, TP, 1608
2203-002002	C453	1	0.033nF, 5%, 50V, NP0, TP, 1608
2203-002002	C454	1	0.033nF, 5%, 50V, NP0, TP, 1608
2203-002002	C459	1	0.033nF, 5%, 50V, NP0, TP, 1608
2203-002002	C515	1	0.033nF, 5%, 50V, NP0, TP, 1608
2203-002002	C516	1	0.033nF, 5%, 50V, NP0, TP, 1608
2203-002002	C517	1	0.033nF, 5%, 50V, NP0, TP, 1608
2203-002002	C518	1	0.033nF, 5%, 50V, NP0, TP, 1608
2203-002002	C519	1	0.033nF, 5%, 50V, NP0, TP, 1608
2203-002398	C524	1	22nF, 10%, 50V, X7R, TP, 1608
2203-005249	C061	1	100nF, 10%, 50V, X7R, TP, 1608
2203-005249	C151	1	100nF, 10%, 50V, X7R, TP, 1608
2203-005249	C152	1	100nF, 10%, 50V, X7R, TP, 1608
2203-005249	C153	1	100nF, 10%, 50V, X7R, TP, 1608
2203-005249	C154	1	100nF, 10%, 50V, X7R, TP, 1608
2203-005249	C162	1	100nF, 10%, 50V, X7R, TP, 1608
2203-005249	C163	1	100nF, 10%, 50V, X7R, TP, 1608
2203-005249	C220	1	100nF, 10%, 50V, X7R, TP, 1608
2203-005249	C221	1	100nF, 10%, 50V, X7R, TP, 1608
2203-005249	C251	1	100nF, 10%, 50V, X7R, TP, 1608
2203-005249	C252	1	100nF, 10%, 50V, X7R, TP, 1608
2203-005249	C253	1	100nF, 10%, 50V, X7R, TP, 1608
2203-005249	C254	1	100nF, 10%, 50V, X7R, TP, 1608

OUTDOOR MAIN PBA(DB92-02866D)

2203-005249	C302	1	100nF, 10%, 50V, X7R, TP, 1608
2203-005249	C303	1	100nF, 10%, 50V, X7R, TP, 1608
2203-005249	C304	1	100nF, 10%, 50V, X7R, TP, 1608
2203-005249	C305	1	100nF, 10%, 50V, X7R, TP, 1608
2203-005249	C306	1	100nF, 10%, 50V, X7R, TP, 1608
2203-005249	C307	1	100nF, 10%, 50V, X7R, TP, 1608
2203-005249	C401	1	100nF, 10%, 50V, X7R, TP, 1608
2203-005249	C402	1	100nF, 10%, 50V, X7R, TP, 1608
2203-005249	C403	1	100nF, 10%, 50V, X7R, TP, 1608
2203-005249	C407	1	100nF, 10%, 50V, X7R, TP, 1608
2203-005249	C420	1	100nF, 10%, 50V, X7R, TP, 1608
2203-005249	C424	1	100nF, 10%, 50V, X7R, TP, 1608
2203-005249	C460	1	100nF, 10%, 50V, X7R, TP, 1608
2203-005249	C503	1	100nF, 10%, 50V, X7R, TP, 1608
2203-005249	C509	1	100nF, 10%, 50V, X7R, TP, 1608
2203-005249	C511	1	100nF, 10%, 50V, X7R, TP, 1608
2203-005249	C514	1	100nF, 10%, 50V, X7R, TP, 1608
2203-005249	C520	1	100nF, 10%, 50V, X7R, TP, 1608
2203-005249	C521	1	100nF, 10%, 50V, X7R, TP, 1608
2203-005249	C525	1	100nF, 10%, 50V, X7R, TP, 1608
2203-005249	C526	1	100nF, 10%, 50V, X7R, TP, 1608
2203-005249	C527	1	100nF, 10%, 50V, X7R, TP, 1608
2203-005249	C701	1	100nF, 10%, 50V, X7R, TP, 1608
2203-005249	C702	1	100nF, 10%, 50V, X7R, TP, 1608
2203-005249	C703	1	100nF, 10%, 50V, X7R, TP, 1608
2203-005249	C704	1	100nF, 10%, 50V, X7R, TP, 1608
2203-005249	C903	1	100nF, 10%, 50V, X7R, TP, 1608
2203-006158	C201	1	100nF, 10%, 16V, X7R, TP, 1005, 0.5T
2203-006158	C203	1	100nF, 10%, 16V, X7R, TP, 1005, 0.5T
2203-006158	C204	1	100nF, 10%, 16V, X7R, TP, 1005, 0.5T
2203-006158	C206	1	100nF, 10%, 16V, X7R, TP, 1005, 0.5T
2203-006158	C207	1	100nF, 10%, 16V, X7R, TP, 1005, 0.5T
2203-006158	C208	1	100nF, 10%, 16V, X7R, TP, 1005, 0.5T
2203-006158	C210	1	100nF, 10%, 16V, X7R, TP, 1005, 0.5T
2203-006158	C211	1	100nF, 10%, 16V, X7R, TP, 1005, 0.5T
2203-006158	C212	1	100nF, 10%, 16V, X7R, TP, 1005, 0.5T
2203-006460	C522	1	2200nF, 10%, 16V, X5R, TP, 1608, -
2203-006960	C902	1	1000nF, 10%, 50V, X7R, TP, 2012
2203-007456	C202	1	1000nF, 10%, 25V, X5R, TP, 1005, 0.5T
2203-007456	C205	1	1000nF, 10%, 25V, X5R, TP, 1005, 0.5T
2203-007456	C209	1	1000nF, 10%, 25V, X5R, TP, 1005, 0.5T
2203-007456	C213	1	1000nF, 10%, 25V, X5R, TP, 1005, 0.5T
2203-007456	C214	1	1000nF, 10%, 25V, X5R, TP, 1005, 0.5T
2203-007456	C226	1	1000nF, 10%, 25V, X5R, TP, 1005, 0.5T
2203-007456	C227	1	1000nF, 10%, 25V, X5R, TP, 1005, 0.5T
2203-007456	C228	1	1000nF, 10%, 25V, X5R, TP, 1005, 0.5T
2203-007456	C229	1	1000nF, 10%, 25V, X5R, TP, 1005, 0.5T
2402-001183	CE451	1	22uF, 20%, 16V, WT, TP, 5.3X5.3X6MM
2402-001268	CE153	1	100uF, 20%, 25V, WT, TP, 8x6.3mm
2402-001268	CE404	1	100uF, 20%, 25V, WT, TP, 8x6.3mm
2402-001268	CE420	1	100uF, 20%, 25V, WT, TP, 8x6.3mm
2402-001368	CE401	1	47uF, 20%, 25V, TP, 6.3x4.9mm
2402-001368	CE402	1	47uF, 20%, 25V, TP, 6.3x4.9mm
2402-001368	CE403	1	47uF, 20%, 25V, TP, 6.3x4.9mm
2802-001165	X201	1	4MHZ, 0.5%, TP, 4.5x2.0x1.15mm
2802-001211	X501	1	8MHZ, 0.1%, TP, 3.2X1.3X0.9 MM
DB41-01227A	PCB MAIN	1	FR-4, 2Layer, 142*197, PF#2, OUTDOOR, 20z, 142*197
DB91-01517A	IC501	1	Soc 1Phase PF2, PF3, STM-125F-OA, HART-I910, 64LQFP, ROM 64KB
0903-001843	-	1	HART-I910, LQFP, 64Z30, 12x12mm, 8MHz, 5V, 600mW, -40to+85C, 12KB, 64KB, Inverter SOC, Inverter SOC
DB98-31449A	ASSY-LABEL MICOM	1	QFP, 64P, WHT, 9*9
DB91-01615A	IC201	1	RAC A3050 Outdoor Micom Nordic, STM-140B-OA, S3FM02G, 128TQFP, ROM 384KB
DB09-00596A	-	1	S3FM02G, 128P, DC3V, TQFP, -40~+85, 384K
DB98-31449A	ASSY-LABEL MICOM	1	QFP, 64P, WHT, 9*9

6-3 ASSY WIFI PCB

■ ASSY WIFI PCB

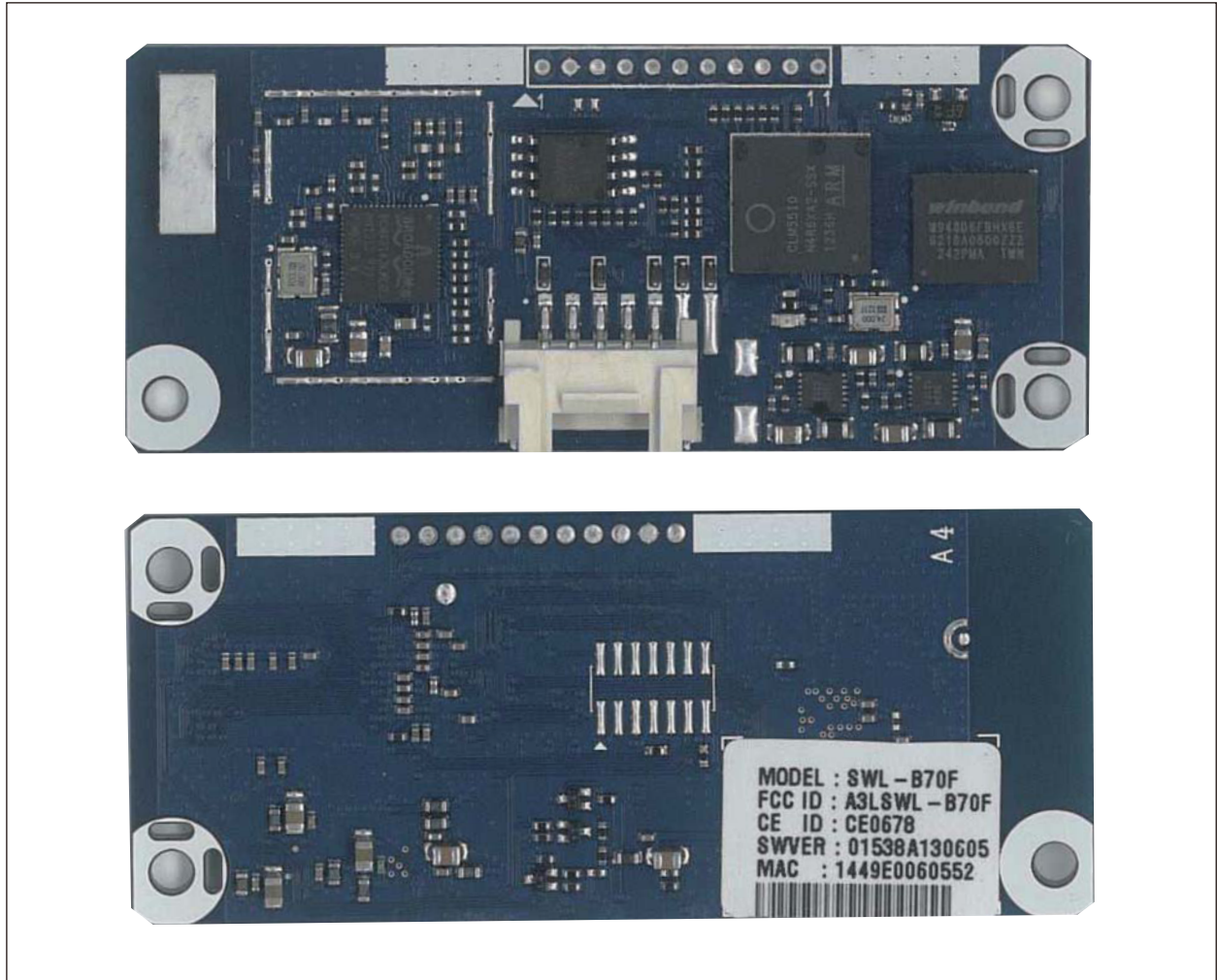

■ CONVERTER PBA

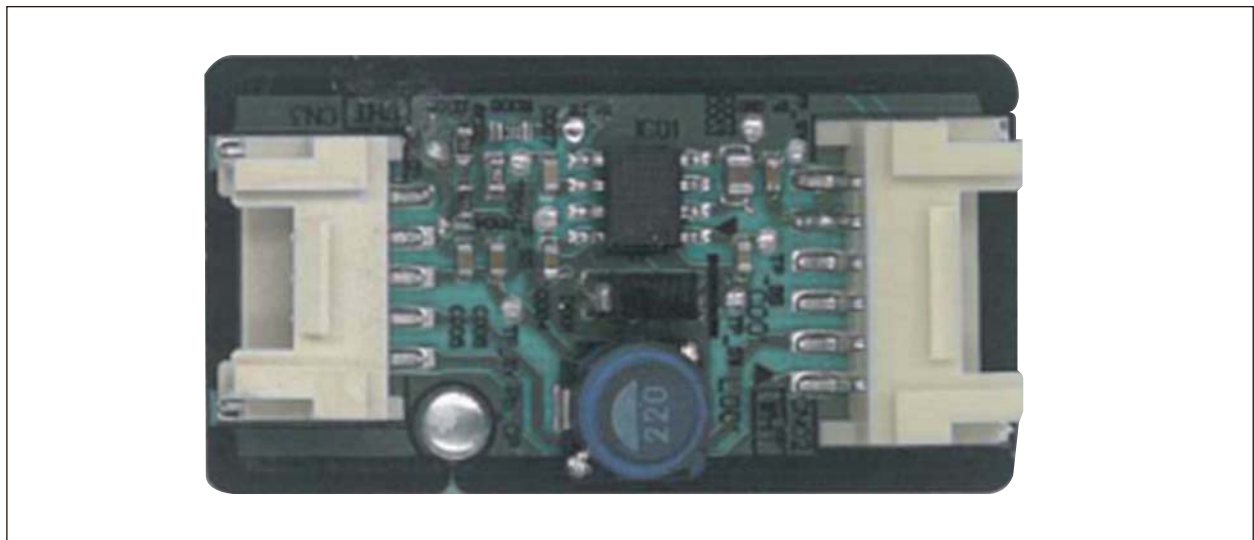

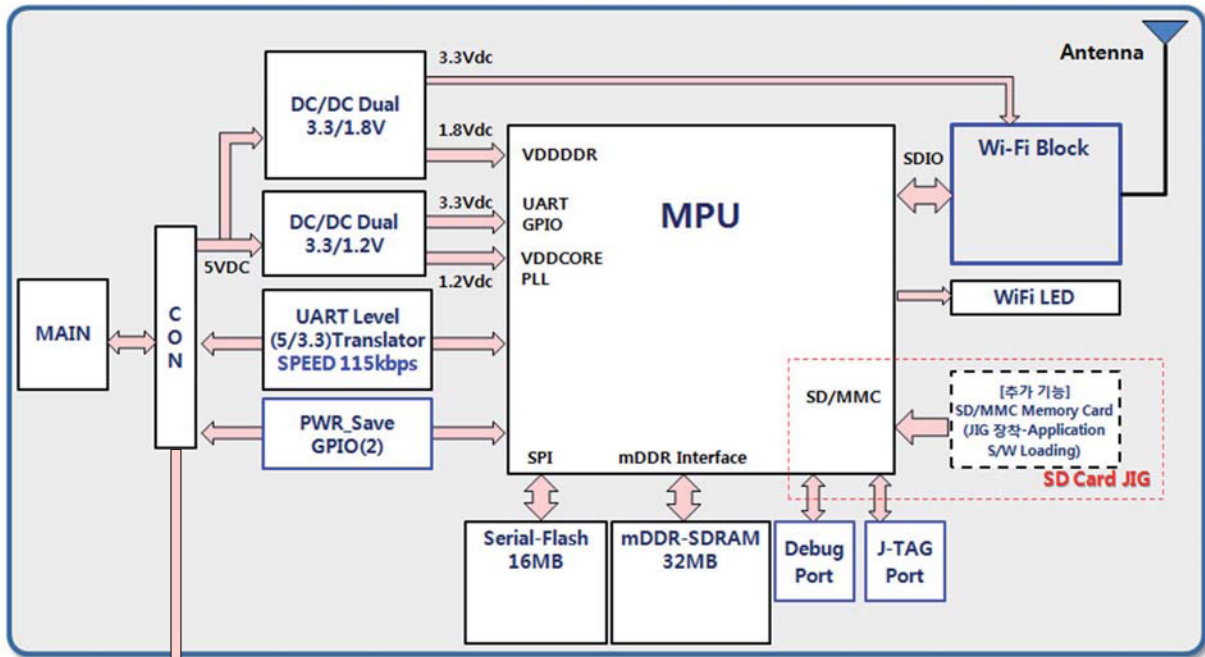

- 1 - nRST
- 2 - GND
- 3 - 5V
- 4 - UART RX
- 5 - UART TX

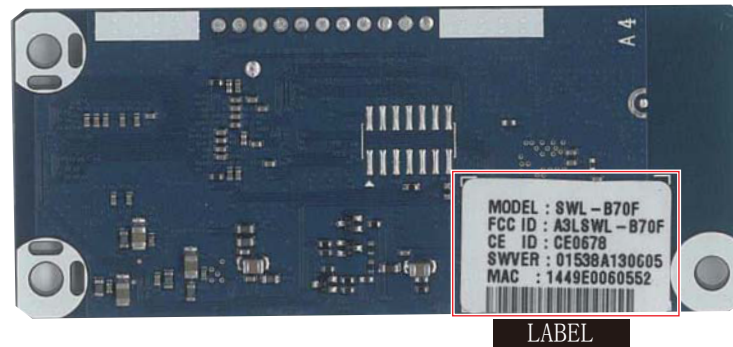
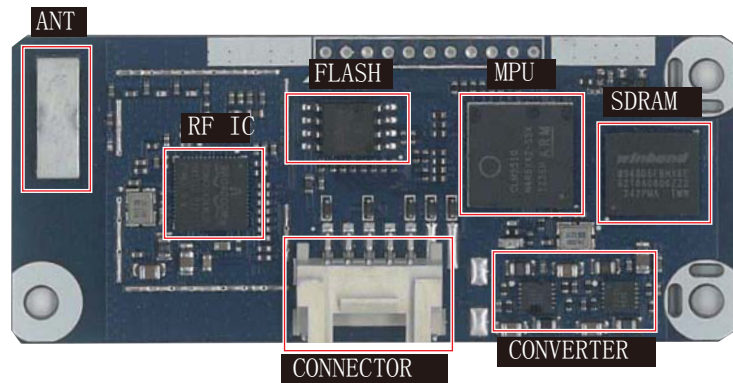

7. Wiring Diagram

7-1 Indoor Unit

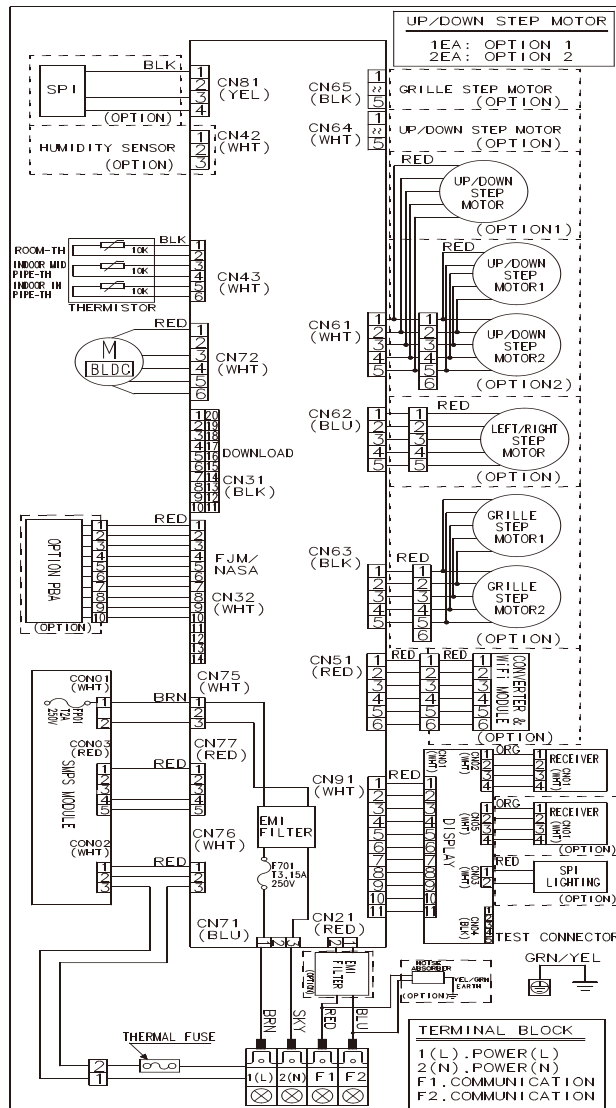

* NOTE - THERMISTOR MARK BASED ON THE TEMP 25°C

7-SEG	ERROR MODE			DESCRIPTION
	LED1 OPERATION	LED2 TIMER	LED3 OPTION	
E101, E102	○	●	●	Communication error (indoor <-> outdoor)
E121	○	○	○	ROOM TH sensor error
E122, E123	●	●	○	INDOOR MID, INDOOR IN PIPE-TH sensor error
E154	○	○	●	Fan error(indoor)
E162	●	●	●	EEPROM error
E163	●	●	●	Option error
FROM E200	●	○	●	Outdoor error display
E422	○	○	●	EEV or Valve Close error-Self diagnosis

● : LAMP ON ○ : LAMP OFF ● : LAMP BLINK
 * Note *
 If the Set doesn't work (No power), check the Thermal fuse of Terminal block OPEN or SHORT with Multimeter.
 * Measure the Thermal fuse housing PIN#1 ~ 2 :
 OPEN(disconnection) -> defective product

CODE NO: DB68-04014A INDOOR-UNIT



DB68-04014A-1

7-2 Outdoor Unit

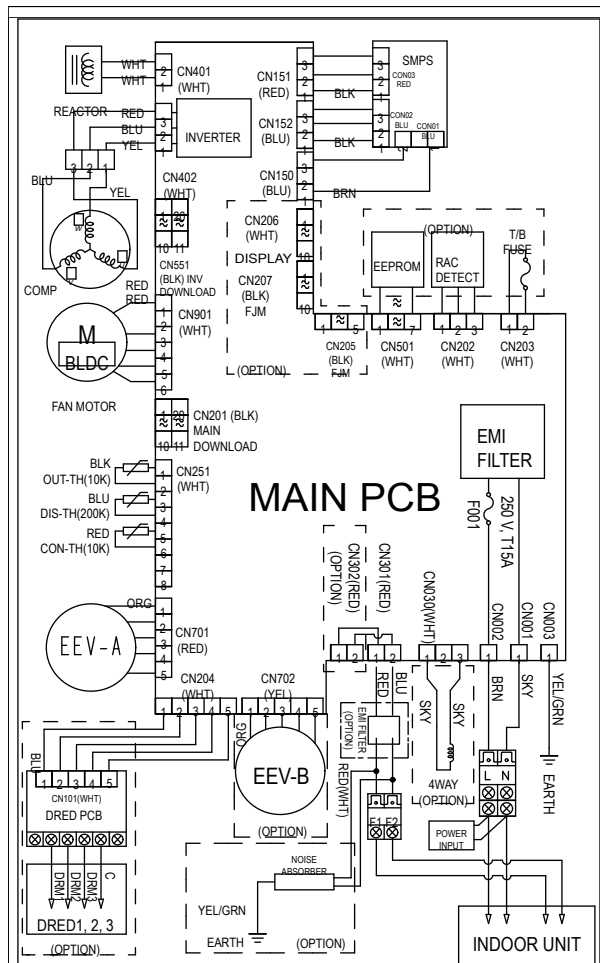

※ NOTE1-THERMISTOR MARK BASED ON THE TEMP 25°C

LED PATTERN	7SEG DISPLAY	DESCRIPTION
YEL GRN RED		POWER OFF / VDD NG
● ● ● ● ● ● ●		Power ON reset (1sec)
○ ○ ○ ○ ○ ○ ○		NORMAL OPERATION
○ ○ ○ ○ ○ ○ ○		Abnormal Communication (Indoor ↔ Outdoor)
○ ○ ○ ○ ○ ○ ○	E464	IPM Over Current(O.C) Error
○ ○ ○ ○ ○ ○ ○	E461	Comp Starting Error
○ ○ ○ ○ ○ ○ ○	E470	EEPROM Data Error (no data)
○ ○ ○ ○ ○ ○ ○	E466	DC-Link Voltage Under/Over Error
○ ○ ○ ○ ○ ○ ○	E484	PFC Over Load Error
○ ○ ○ ○ ○ ○ ○	E483	Over Voltage Protection Error
○ ○ ○ ○ ○ ○ ○	E221	OUT-TH (Outdoor Temperature) Sensor Error
○ ○ ○ ○ ○ ○ ○	E416	DIS-TH (Discharge Temperature) Over Error
○ ○ ○ ○ ○ ○ ○	E251	DIS-TH (Discharge Temperature) Sensor Error
○ ○ ○ ○ ○ ○ ○	E468	Current Sensor Error
○ ○ ○ ○ ○ ○ ○	E474	Heatsink Sensor Error
○ ○ ○ ○ ○ ○ ○	E485	Input Current Sensor Error
○ ○ ○ ○ ○ ○ ○	E485	Comp V limit / I limit Error
○ ○ ○ ○ ○ ○ ○	E500	Heatsink Over Temperature Error
○ ○ ○ ○ ○ ○ ○	E231	CON-TH (Cond Temperature) Sensor Error
○ ○ ○ ○ ○ ○ ○	E203	Time out Comm. (Inv Micom ↔ Main Micom)
○ ○ ○ ○ ○ ○ ○	E458	Fan Error
○ ○ ○ ○ ○ ○ ○	E471	EEPROM Data Error (Main Micom ↔ Inv Micom)
○ ○ ○ ○ ○ ○ ○	E467	Comp Wire Missing Error
○ ○ ○ ○ ○ ○ ○	E440	Prohibit Operation Condition Error (Heating)
○ ○ ○ ○ ○ ○ ○	E441	Prohibit Operation Condition Error (Cooling)
○ ○ ○ ○ ○ ○ ○	E469	DC-Link Voltage Sensor Error
○ ○ ○ ○ ○ ○ ○	E488	AC Input Voltage Sensor Error
○ ○ ○ ○ ○ ○ ○	E462	AC Input L Limit Trip Error
○ ○ ○ ○ ○ ○ ○	E554	Gas Leak Error
○ ○ ○ ○ ○ ○ ○	E422	EEV or Valve Close error-Self diagnosis
○ ○ ○ ○ ○ ○ ○	-	Test Operation at Cooling Mode
○ ○ ○ ○ ○ ○ ○	-	Test Operation at Heating Mode

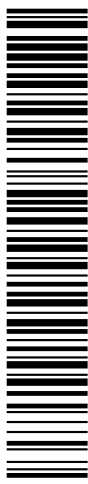

DB68-04015A-00

● LED ON ○ LED OFF ◎ LED BLINKING
DB68-04015A OUTDOOR UNIT

7-3 ASSY WIFI KIT

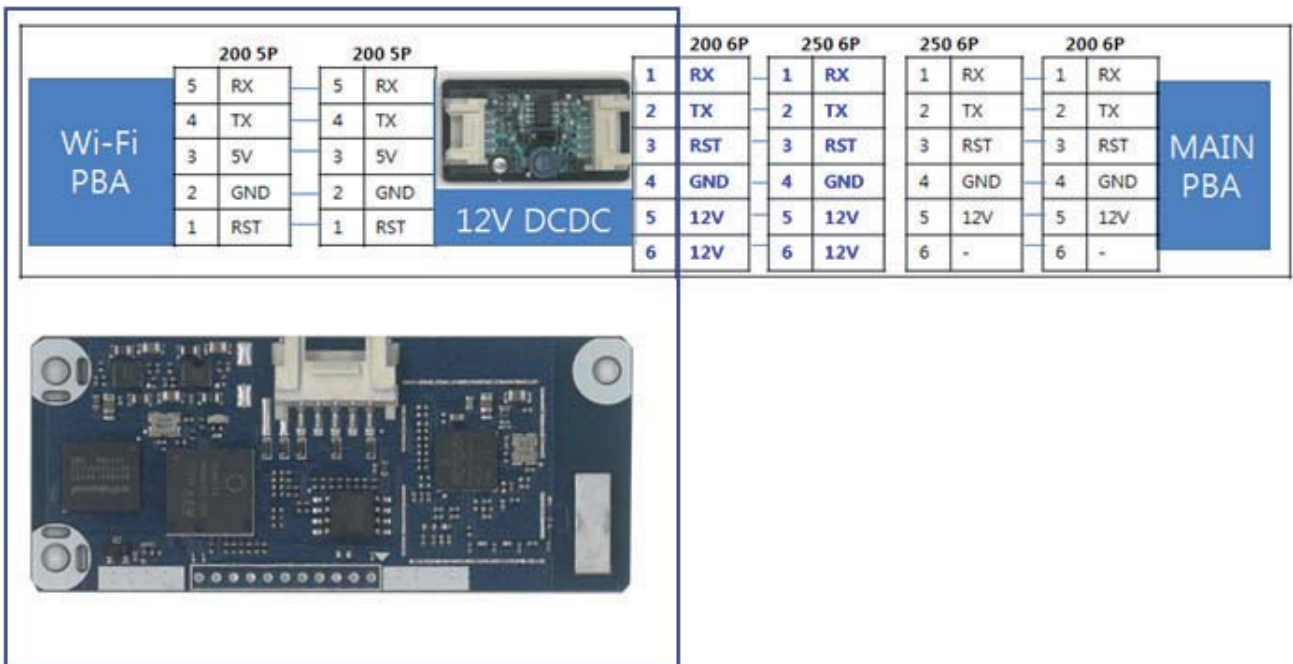
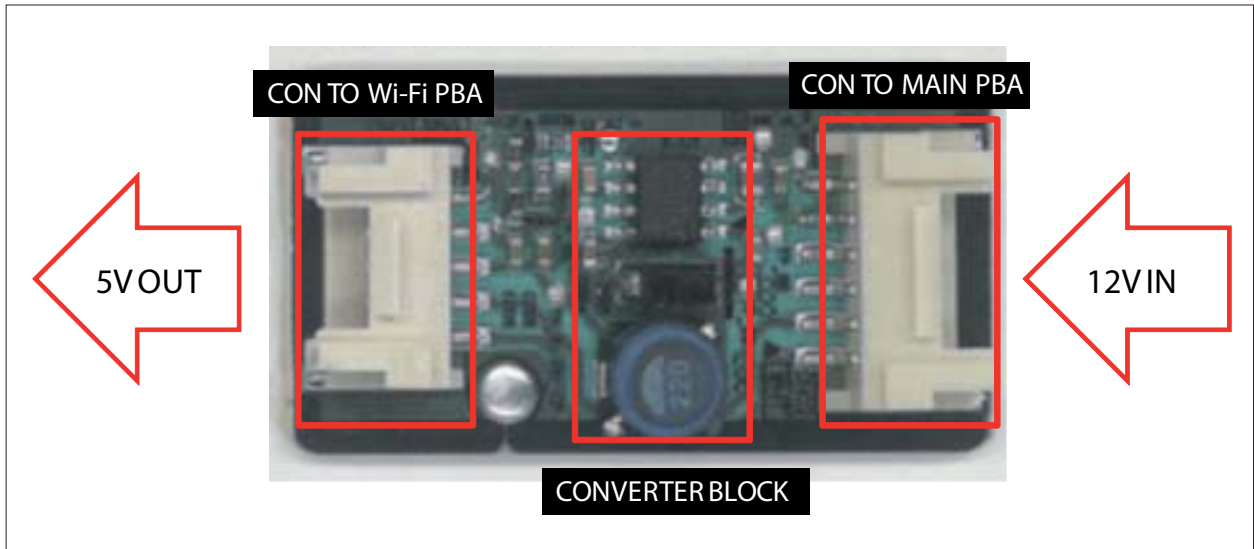
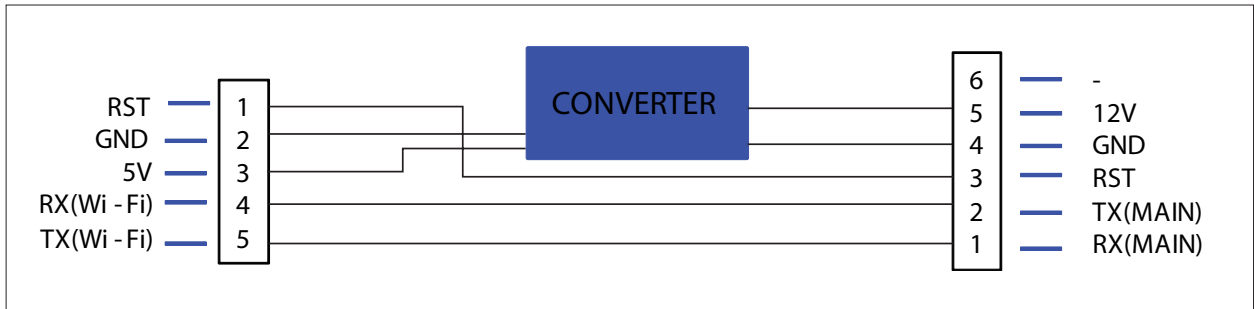

8. PCB Diagram

8-1 Indoor PCB

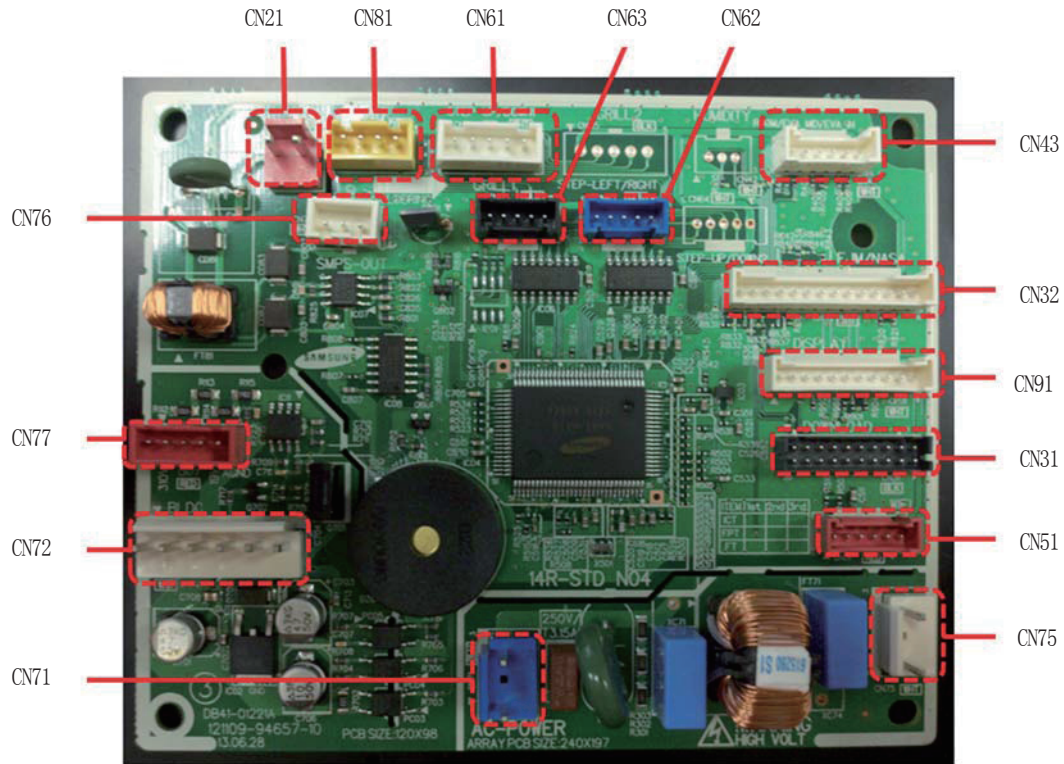

① CN61/CN62/CN63 - STEP MOTOR #1: DC 12V #2~#5 :STEP MOTOR SIGNAL	② CN71 - POWER IN #1, #3 : AC220~240V #2 : N.C	③ CN81 - SPI #1: SPI SIGNAL #3 : DC 12V	④ CN51 - WI-FI MODULE #1 : WIFI UART SIGNAL1 #2 : WIFI UART SIGNAL2 #3 : WIFI RESET SIGNAL #4 : GND #5 : DC 12V #6 : N.C
⑤ CN51 - DISPLAY #1~#11, #14, #17~#20 : MICOM DOWN #12, #13, #15, #16 : N.C	⑥ CN43 - TEMPERATURE SENSOR #1, #2 : ROOM SENSOR #3, #4 : EVA MID SENSOR #5, #6 : EVA IN SENSOR	⑦ CN21 - COMMUNICATION #1, #2 : 485 COMM SIGNAL	⑧ CN72 - BLDC FAN MOTOR #1 : DC 310~340V #2 : N.C #3 : AGND #4 : DC 15V #5 : FAN RPM #6 : FAN FEEDBACK
⑨ CN32 - FJM/NASA #1~#7, #11~ #14 : FJM/NASA SIGNAL #8 : DC 5V #9 : GND #10 : DC 12V	⑩ CN75 - SMPS POWER IN #1, #3 : AC220~240V #2 : N.C	⑪ CN76 - SMPS DC OUT (12V/GND/5V) #1 : DC 5V #2 : GND #3 : DC 12V	⑫ CN77 - SMPS DC OUT (19V/GND/310V) #1 : DC 310V~340V #2, #3 : N.C #4 : DC 19V~27V #5 : AGND
⑬ CN31 - DOWNLOAD DOWNLOAD			

8-2 Outdoor PCB

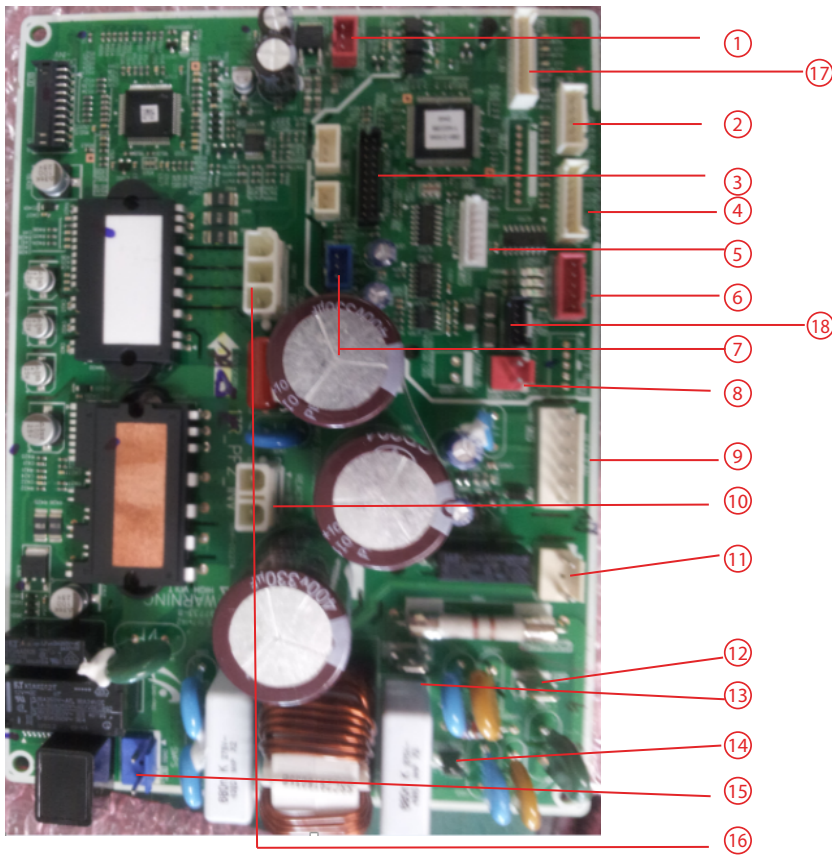

⑰ CN206 Heater Drive signal
#1: Heater 1 Signal
#2: Heater 2 Signal
⑱ CN205 DC Power
#1: 12V
#2: GND

① CN151 - SMPS INV #1 : 15V #2 : GND #3 : ENABLE	② CN204 - DRED #1 : DRED1 #2 : DRED2 #3 : DRED3 #4 : GND #5 : 5V	③ CN201 - DOWNLOAD-MAIN #1 ~ #20 : DOWNLAOD	④ CN251 - SENSOR #1,#2 : OUT SENSOR #3,#4 : DISCHARGE SENSOR #5,#6 : COND SENSOR
⑤ CN501 - EEPROM #1 : GND #3 : 5V #4 : EEP CS #5 : EEP_SO/MICOM RX #6 : EEP_SI_MICOM_TX #7 : EEP CLK	⑥ CN701 - EEV-A #1~#4 : EEV SIGNAL #5 : 12V	⑦ CN152 - SMPS MAIN #1 : 12V #2 : GND #3 : 5V	⑧ CN301 - COMMUNICATION #1 : F1 #2 : F2
⑨ CN901 - FAN #1 : DC 310~340V #2 : NC #3 : AGND #4 : DC 15V #5 : FAN RPM #6 : FAN FEEDBACK	⑩ CN401 - REACTOR #1 : REACTOR1 #2 : REACTOR2	⑪ CN030 - 4WAY #1,#3 : AC220~240V	⑫ CN001 - POWER-N #1 : N
⑬ CN002 - POWER-L #1 : L	⑭ CN003 - EARTH #1 : EARTH	⑮ CN150 - SMPS AC #1,#3 : AC220~240V	⑯ CN402 - COMP #1 : W #2 : V #3 : U

8-3 Wire connecting the indoor unit terminal blocks

1. Terminal press of Ring terminal shall be set facing up before connecting wire.



Is inverted



Terminal has been cut.

2. There shall be no empty space between Ring terminal and Screw after Clamp.
If not, there exists a possibility of fire which can be caused by electric heat in the connecting part.

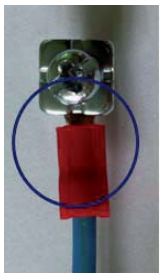

①



②



③

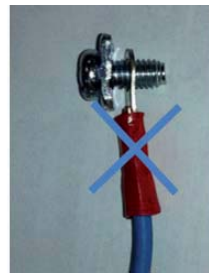

④



⑤



⑥

- ①, ② : Good
③ Bad : Ring terminal is connected reversely
④ Bad : Not clamped Screw
⑤ Bad : In the gap between Ring terminal & Screw
⑥ Bad : Unused Ring Terminal

9. Operating Instructions

9-1 Name of Each Part

9-1-1 Indoor Unit

The design and shape are subject to change according to the model.

■ Main Parts

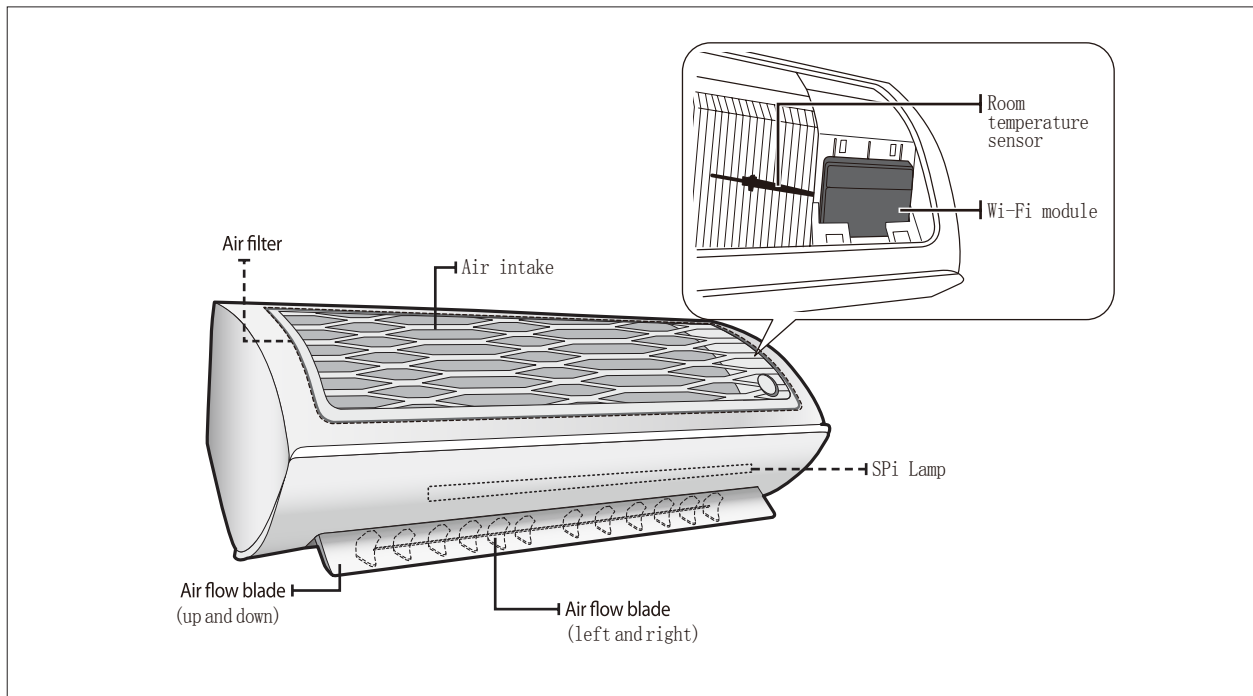

■ Display

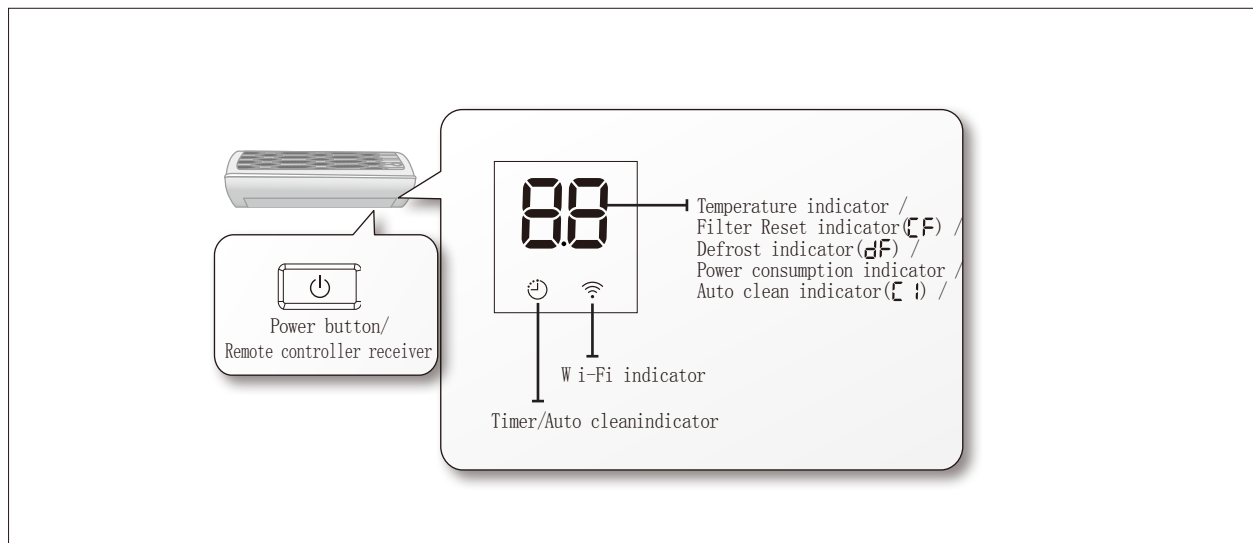

9-2 Wireless Remote Control-Buttons and Display

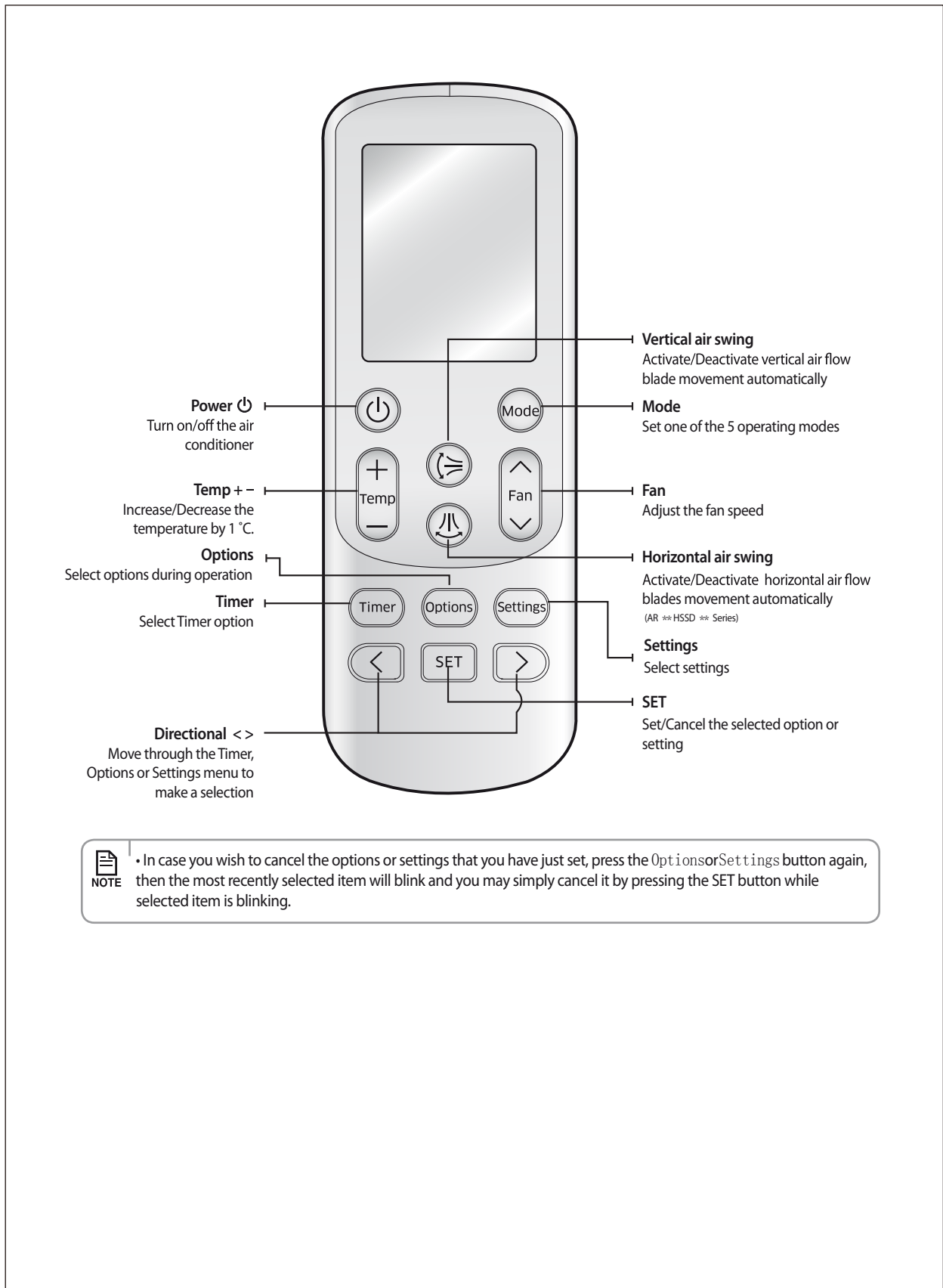

• In case you wish to cancel the options or settings that you have just set, press the **Options** or **Settings** button again, then the most recently selected item will blink and you may simply cancel it by pressing the **SET** button while selected item is blinking.

10. Troubleshooting

10-1 Items to be checked first

Refer to the following chart if the air conditioner operates abnormally. This may save time and unnecessary expenses.

PROBLEM	SOLUTION
The air conditioner does not work at all.	<ul style="list-style-type: none">• power Check status and then operate the air conditioner again.• Plug in or switch on the circuit breaker and then operate the air conditioner again.• Isolator Ensure is switch on.• Check if you have set the Off Timer. Operate the air conditioner again by pressing the Power button.
The temperature adjustment is not working.	<ul style="list-style-type: none">• Check if you have selected Fan/Fast mode. In these modes, desired temperature is set to auto and you cannot adjust the temperature.
Cool/Warm air does not come out of the air conditioner.	<ul style="list-style-type: none">• Check if the set temperature is higher (during Cool mode)/ lower (during Heat mode) than the current temperature. Press the Temp + or - button on the remote controller to change the set temperature.• Check if the Air filter is blocked by dirt. If there is a lot of dust on the Air filter, cooling (heating) performance may decrease. Clean them frequently.• Check if the outdoor unit is covered or installed near the obstacle. Take the cover off and take the obstacle away.• Check if the air conditioner is operating in defrost mode. When the ice formed in winter or the outdoor temperature is too low, the air conditioner operates in defrost mode automatically. In defrost mode, indoor fan stops and warm air does not come out.• If the doors or windows are open, it may cause bad cooling (heating) performance. Close the doors and windows.• Check if the air conditioner has just been turned on after stopping cooling or heating operation. In this case, just a fan will run to protect the outdoor unit compressor.• Check if the pipe length is too long. When the pipe length exceeds maximum allowable pipe length, cooling (heating) performance may decrease.
Air flow adjustment is not working.	<ul style="list-style-type: none">• Check if you have selected good'sleep mode. In this mode, you cannot adjust the air flow direction. (If the good'sleep mode is operating in Heat mode, you can adjust the air flow direction.)

10-1 Items to be checked first

PROBLEM	SOLUTION
Air flow adjustment is not working.	<ul style="list-style-type: none"> • Check if you have selected good'sleep mode. In cool mode, you cannot adjust the air flow direction. (If the good'sleep mode is operating in Heat mode, you can adjust the air flow direction.)
Fan speed adjustment is not working.	<ul style="list-style-type: none"> • Check if you have selected Auto/Dry/Fast/Comfort/good'sleep mode. In these mode, fan speed is set to Auto and you cannot adjust the fan speed.
Remote controller is not working.	<ul style="list-style-type: none"> • Check if your batteries are depleted. • Make sure nothing is blocking your remote controller sensor. • Check that there are strong lighting apparatus near the air conditioner. Strong light which comes from fluorescent bulbs or neon signs may interrupt the electric waves.
Timer function does not set.	<ul style="list-style-type: none"> • Check if you press the SET button on the remote controller after you have set the time.
The indicator is blinking continuously.	<ul style="list-style-type: none"> • Press the Power  button or disconnect the power plug/switch off the auxiliary power switch. If the indicator is still blinking, contact the service center.
Odors permeate in the room during operation.	<ul style="list-style-type: none"> • Check if the appliance is running in a smoky area. Ventilate the room or operate the air conditioner in Fan mode for 1~2 hours. (We do not use smelly components in the air conditioner.) • Check the Drains have been cleared Regular Maintenance.
Error is indicated.	<ul style="list-style-type: none"> • When an indoor unit indicator blinks, contact the nearest service center. Please ensure the error code is passed onto the service center when booking the service call.
Noise is generated.	<ul style="list-style-type: none"> • Depending on the status of the air conditioner usage, noise can be heard when refrigerant flow movement changes. It is normal.
Smoke is generated from the outdoor unit.	<ul style="list-style-type: none"> • If may not be a fire but it can be a steam generated by the defrost operation from outdoor heat exchanger during Heat mode in winter.
Water is dropping from the outdoor unit piping connection.	<ul style="list-style-type: none"> • Water may be generated because of the temperature difference. It is normal.

10-2 Communication Error

10-2-1 Communication Error

Indoor display

3-LED DISPLAY			7-SEG DISPLAY	DESCRIPTION
LED1	LED2	LED3	E101/E102	Communication error(Indoor<->outdoor)
◎	●	●		

Outdoor display

◎	●	●	1min. Time out Comm.
○	○	●	Abnormal Communication
○	●	●	

● LED ON ◎ LED BLINKING ○ LED OFF

1. Checklist :

- 1) Is the cable between the indoor unit and outdoor unit connected correctly?
- 2) Isn't the power cable and communication cable cross?

2. Troubleshooting procedure

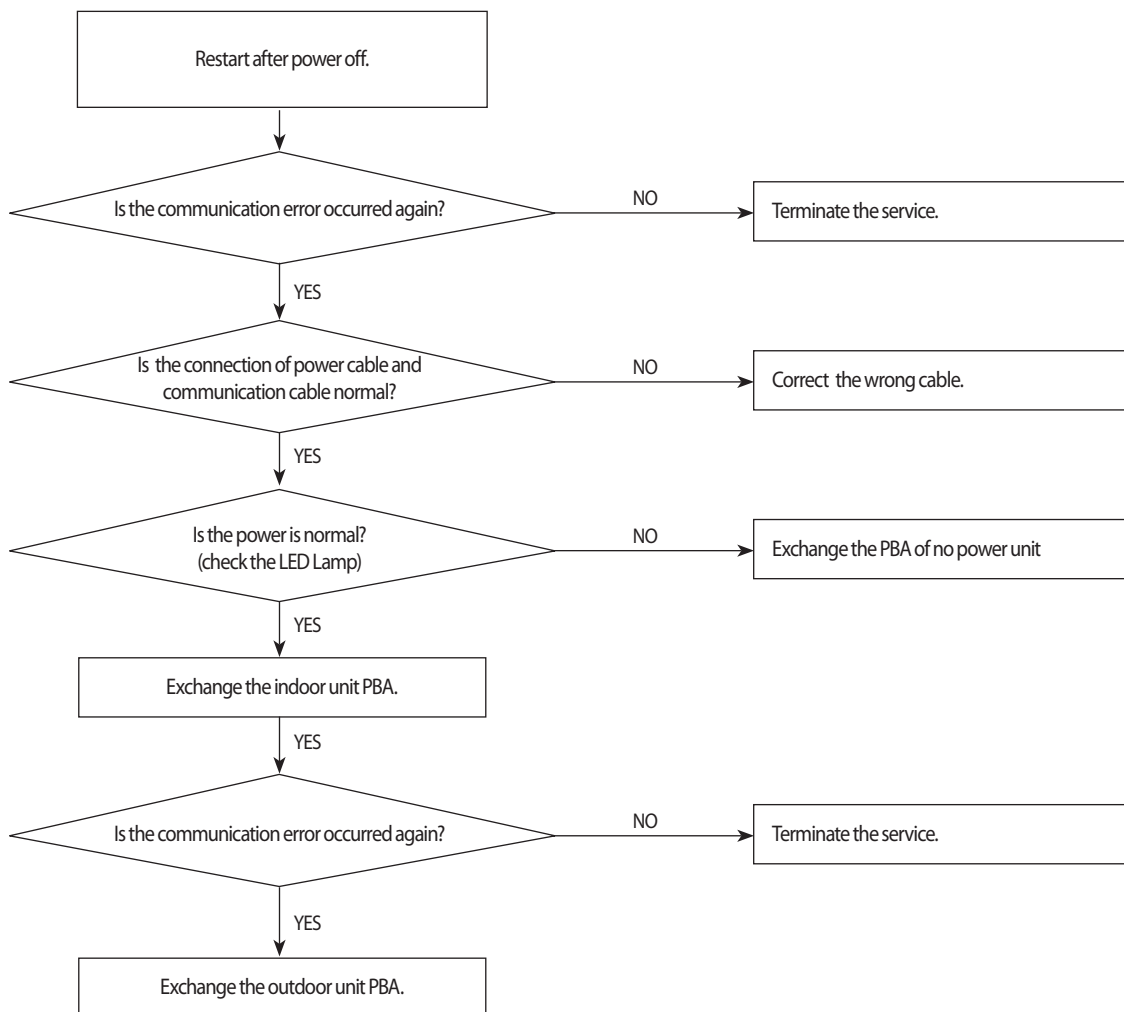

10-2-2 Indoor temperature sensor Error

Indoor display

7-SEG DISPLAY	DESCRIPTION
E121	Indoor room temp sensor error

1. Checklist :

- 1) Is the indoor units temperature sensor connected correctly?
- 2) Is the sensor placed correctly?
- 3) Does the both terminal of sensor satisfy the resistance value in accordance with temperature?

2. Troubleshooting procedure

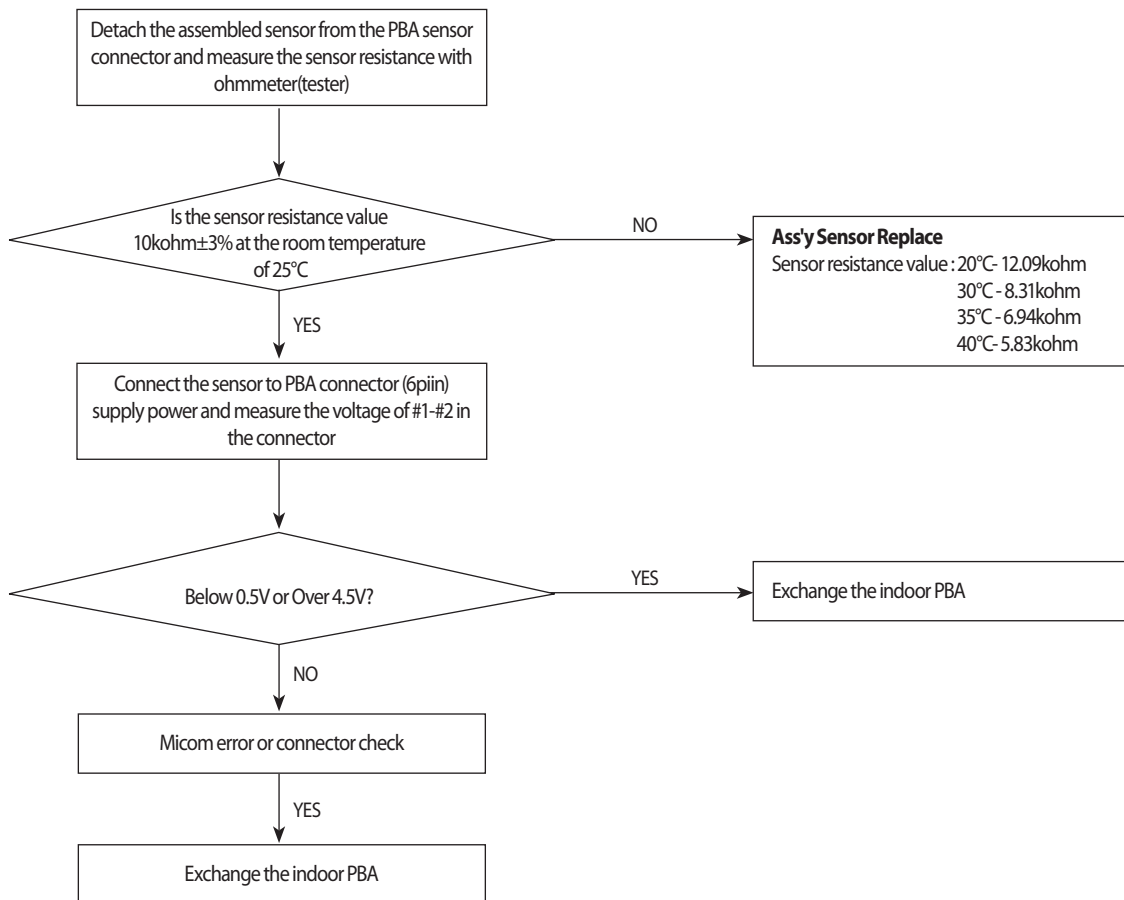

10-2-3 Indoor Eva-in temperature sensor error

Indoor display

3-LED DISPLAY			7-SEG DISPLAY	DESCRIPTION
LED1	LED2	LED3	E122,E123	Indoor MID, Indoor IN PIPE-TH sensor error
⊙	⊙	○		

● LED ON ⊙ LED BLINKING ○ LED OFF

1. Checklist :

- 1) Is the indoor units temperature sensor connected correctly?
- 2) Is the sensor placed correctly?
- 3) Does the both terminal of sensor satisfy the resistance value in accordance with temperature?

2. Troubleshooting procedure

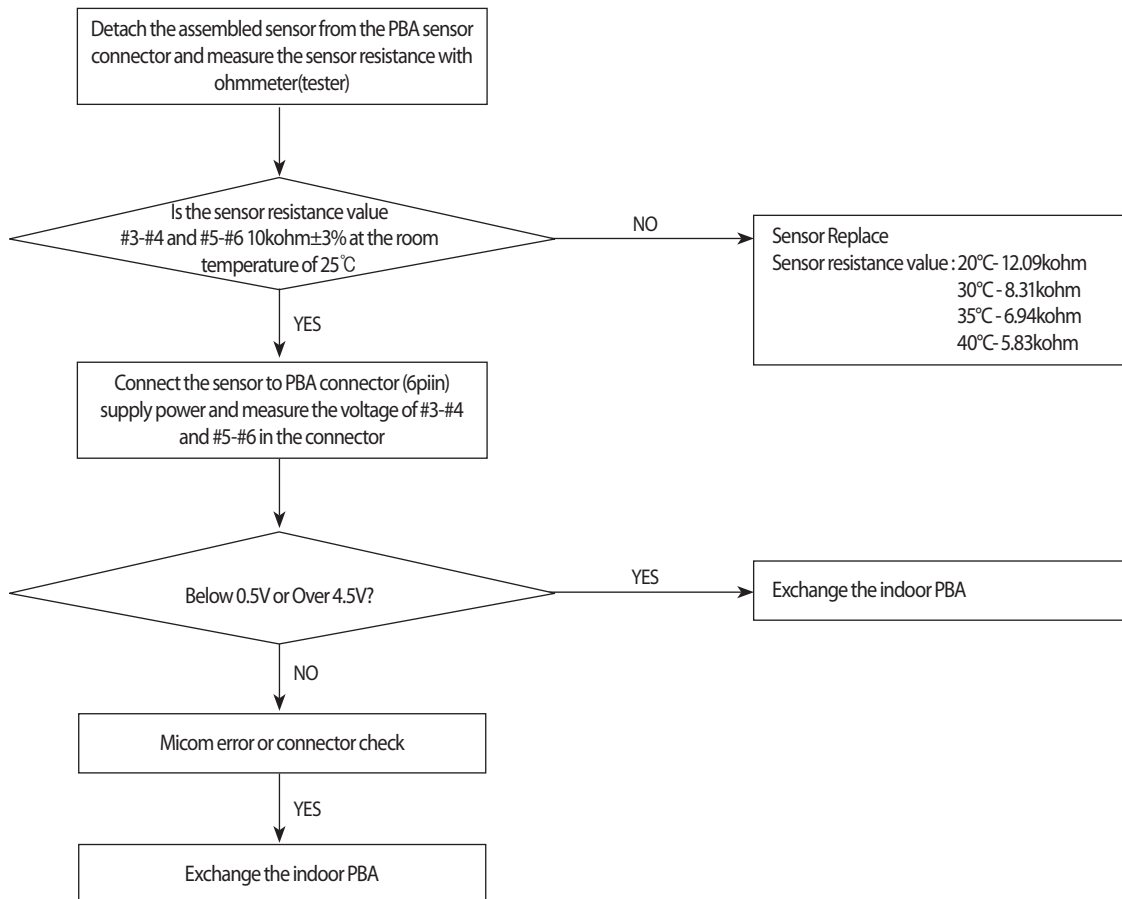

10-2-4 When the Up/Down, Left/Right, Grill louver motor does not operate (Initial Diagnosis) (Not displayed)

1. Checklist :

- 1) Is the input power voltage normal?
- 2) Is the Up/Down louver motor properly connected with the connector? (CN61, CN62, CN63)

2. Troubleshooting procedure

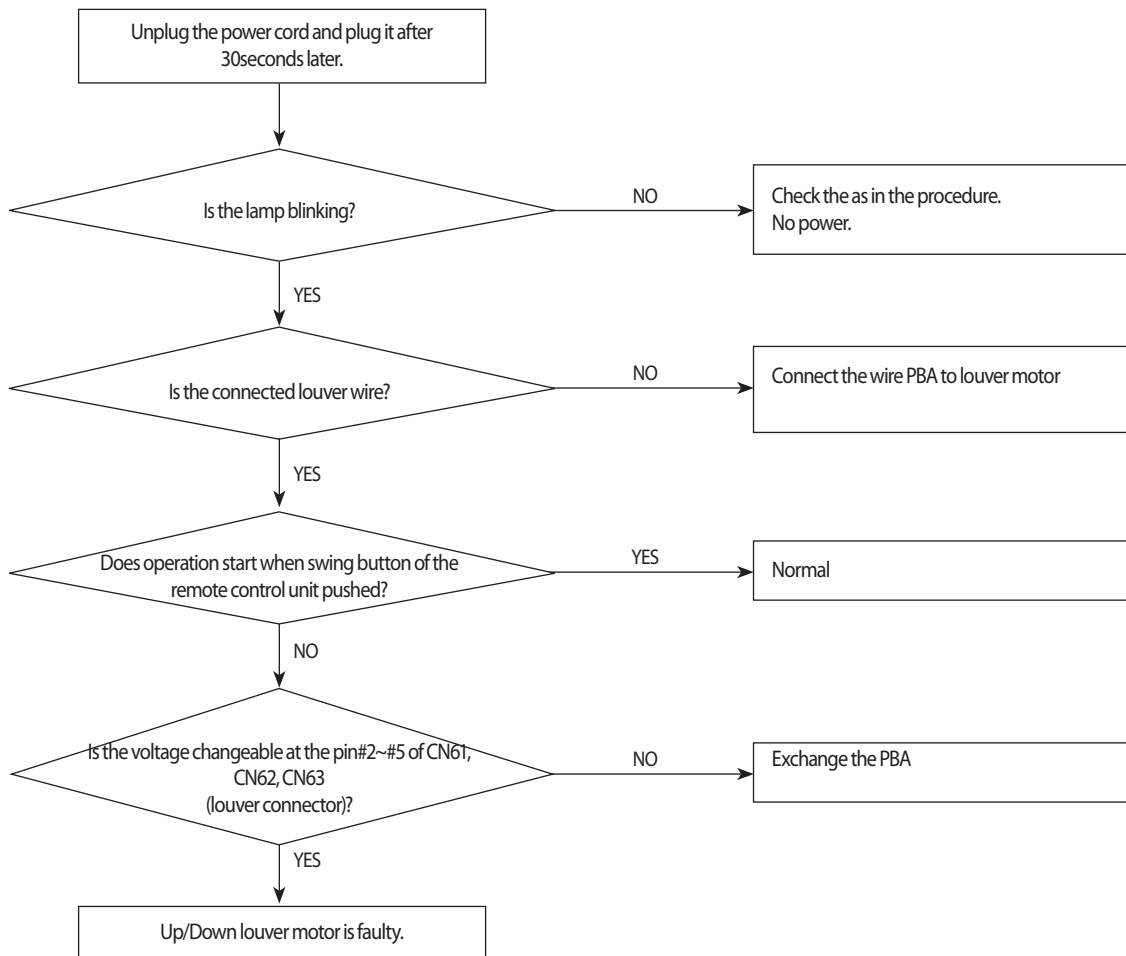

10-2-5 Indoor fan motor speed detecting error (BLDC fan)

Indoor display

3-LED DISPLAY			7-SEG DISPLAY	DESCRIPTION
LED1	LED2	LED3	E154	Indoor fan error
○	○	◎		

● LED ON ◎ LED BLINKING ○ LED OFF

1. Checklist :

- 1) Is the indoor units fan motor properly connected with the connector(CN72)?
- 2) Is the AC voltage correct?

2. Troubleshooting procedure

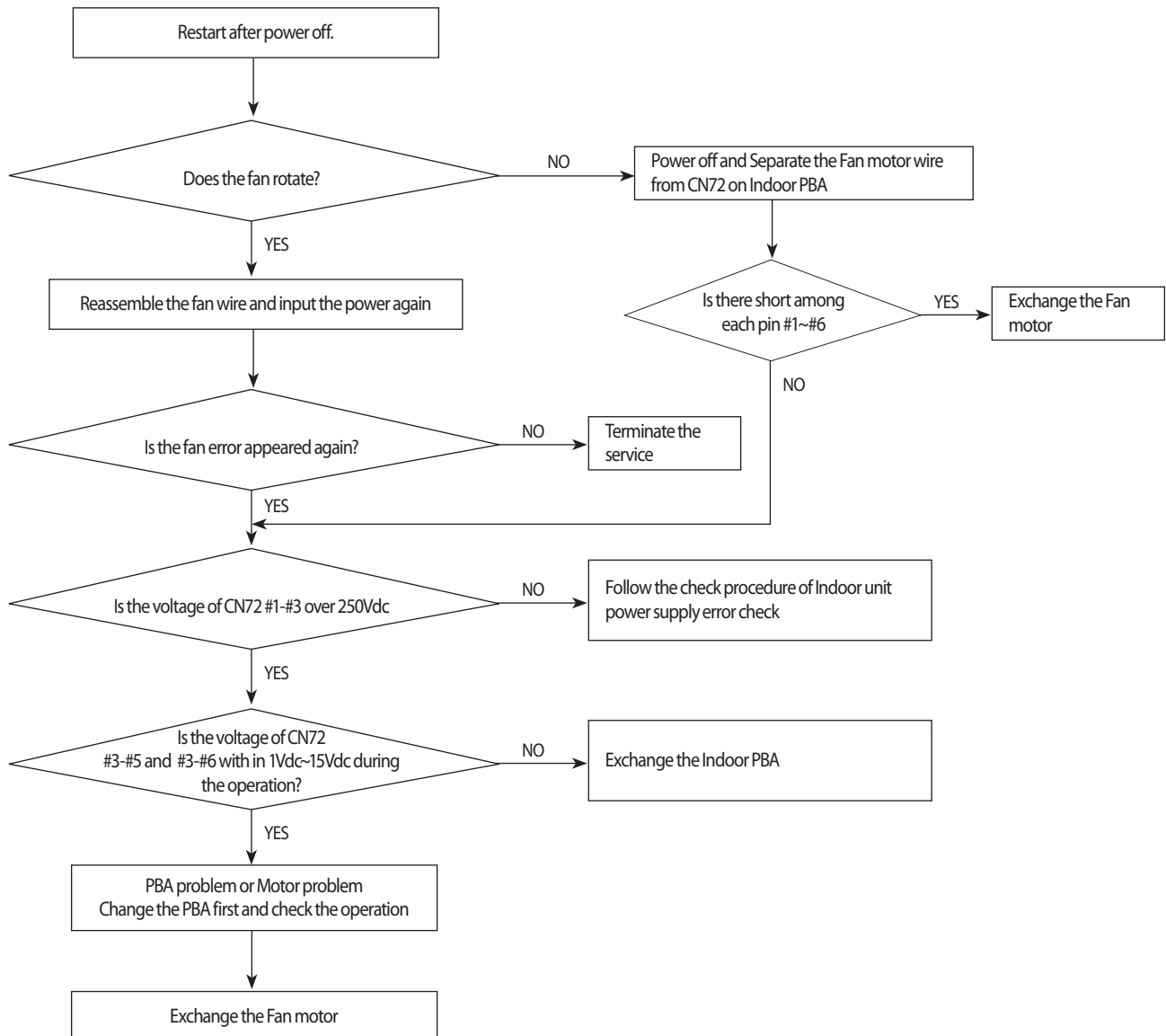

10-2-6 Outdoor temperature sensor error

Indoor display

3-LED DISPLAY			7-SEG DISPLAY	DESCRIPTION
LED1	LED2	LED3	E221	Outdoor temperature sensor error
⊙	○	⊙		

Outdoor display

⊙	○	⊙	Outdoor temperature sensor error
---	---	---	----------------------------------

● LED ON ⊙ LED BLINKING ○ LED OFF

1. Checklist :

- 1) Is the sensor connected correctly?
- 2) Is the sensor placed correctly?
- 3) Does the both terminal of sensor satisfy the resistance value in accordance with temperature?
- 4) Is the resistance value of sensor connection pull-up correct?

MODEL	"A"	"B"
ALL	CN251	CN251 #1-#2

2. Troubleshooting procedure

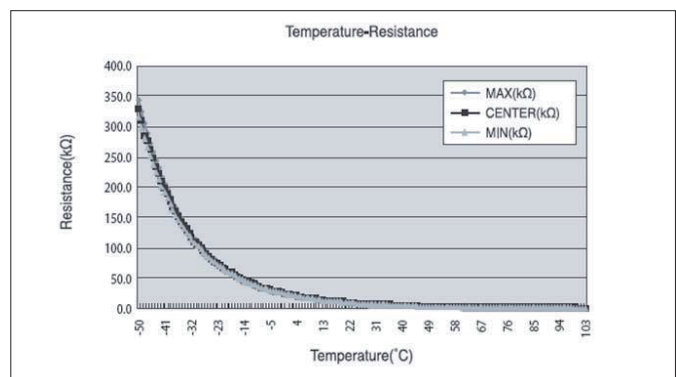
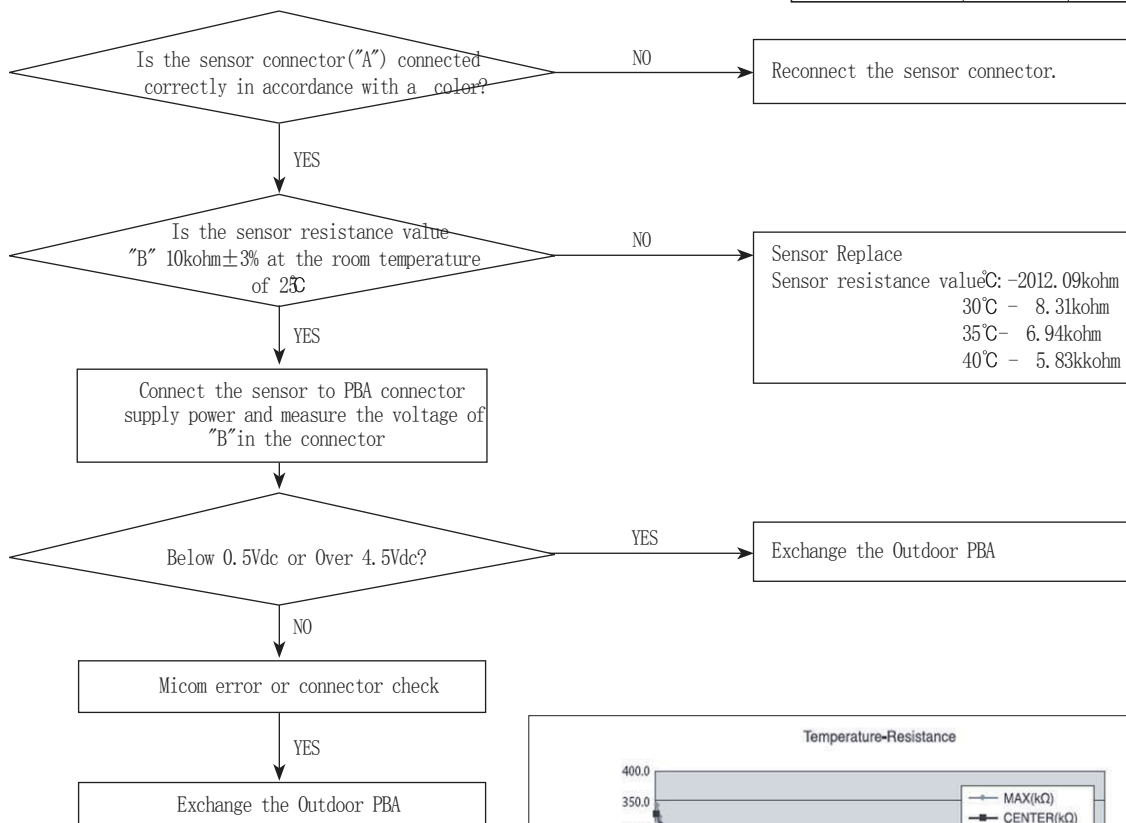

10-2-7 Outdoor Cond temperature sensor error

Indoor display

3-LED DISPLAY			7-SEG DISPLAY	DESCRIPTION
LED1	LED2	LED3	E231	Outdoor Cond temperature sensor error
⊙	○	⊙		

Outdoor display

⊙	●	⊙	Outdoor Cond temperature sensor error
---	---	---	---------------------------------------

● LED ON ⊙ LED BLINKING ○ LED OFF

1. Checklist :

- 1) Is the sensor connected correctly?
- 2) Is the sensor placed correctly?
- 3) Does the both terminal of sensor satisfy the resistance value in accordance with temperature?
- 4) Is the resistance value of sensor connection pull-up correct?

MODEL	"A"	"B"
ALL	CN251	CN251 #5-#6

2. Troubleshooting procedure

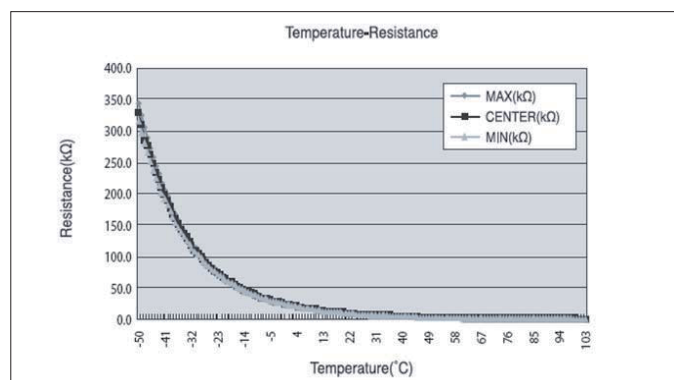
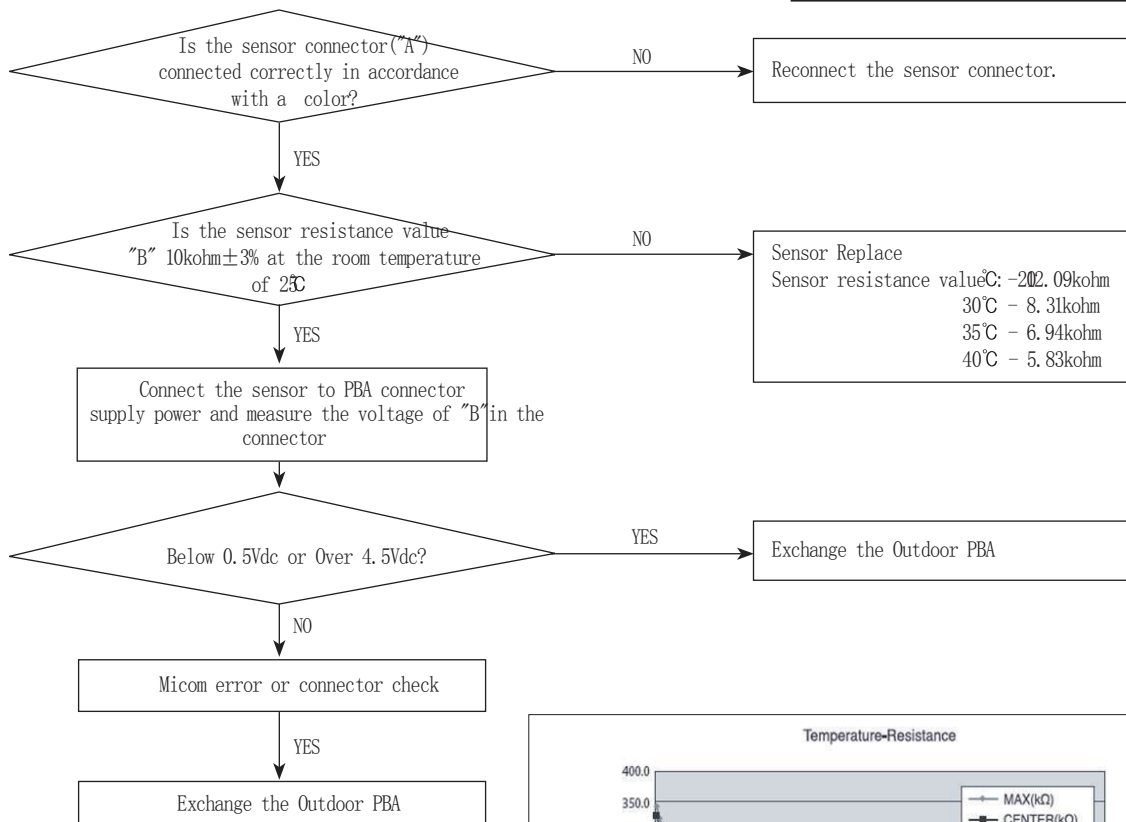

10-2-8 Outdoor Discharge temperature sensor error

Indoor display

3-LED DISPLAY			7-SEG DISPLAY	DESCRIPTION
LED1	LED2	LED3	E251	Outdoor Discharge temperature sensor error
⊙	○	⊙		

Outdoor display

⊙	⊙	○	Outdoor Discharge temperature sensor error
---	---	---	--

● LED ON ⊙ LED BLINKING ○ LED OFF

1. Checklist :

- 1) Is the sensor connected correctly?
- 2) Is the sensor placed correctly?
- 3) Does the both terminal of sensor satisfy the resistance value in accordance with temperature?
- 4) Is the resistance value of sensor connection pull-up correct?

MODEL	"A"	"B"
ALL	CN251	CN251 #3-#4

2. Troubleshooting procedure

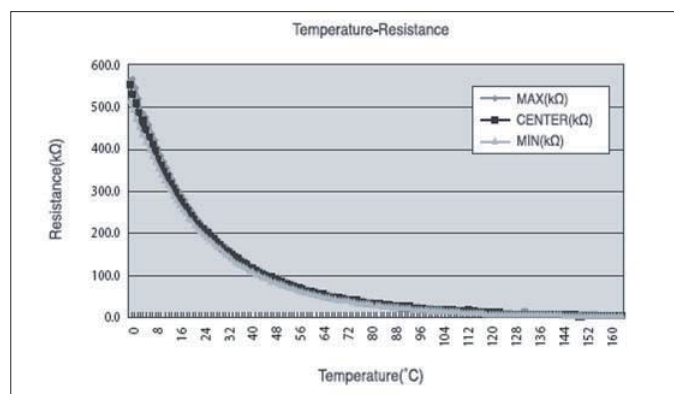
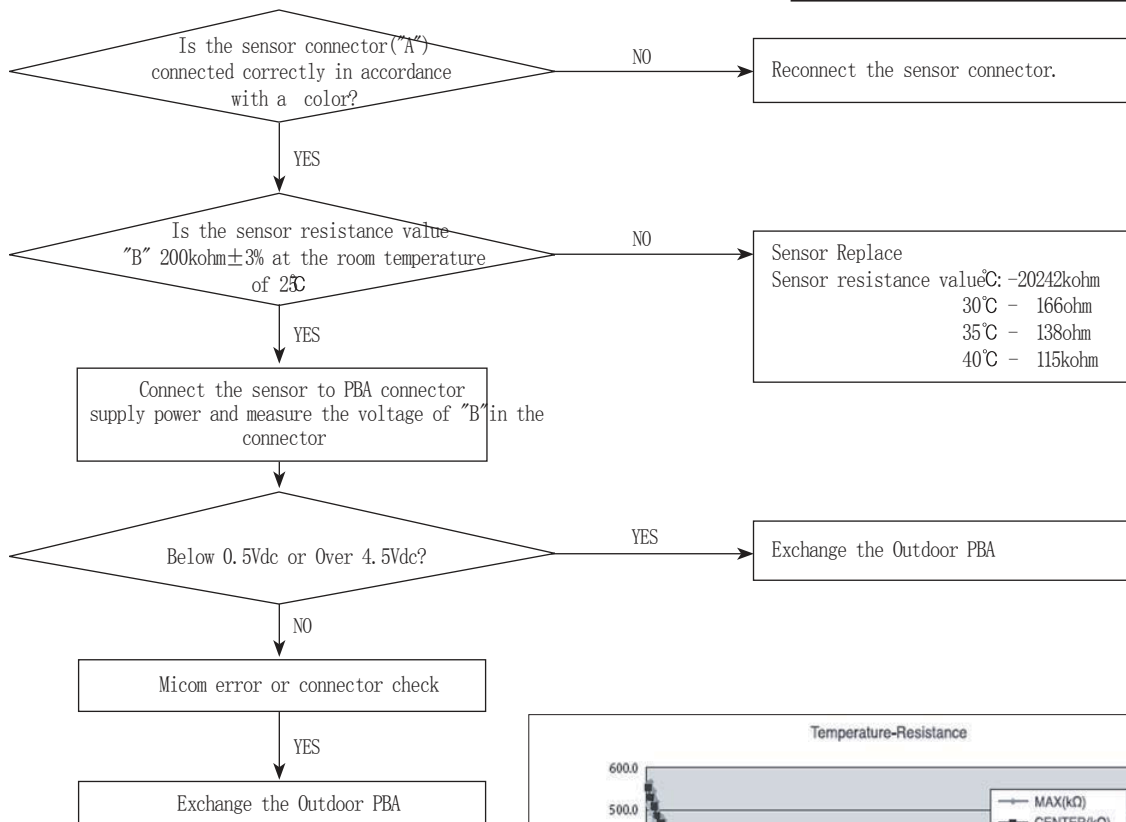

10-2-9 Outdoor Discharge over temperature error

Indoor display

3-LED DISPLAY			7-SEG DISPLAY	DESCRIPTION
LED1	LED2	LED3	E416	Outdoor Discharge over temperature error
◎	○	◎		

Outdoor display

◎	◎	●	Outdoor Discharge over temperature error
---	---	---	--

● LED ON ◎ LED BLINKING ○ LED OFF

1. Checklist :

- 1) Check the discharge temperature in the outdoor unit
- 2) Check the compressor locking or gas leak
- 3) Download the EEPROM data

2. Troubleshooting procedure

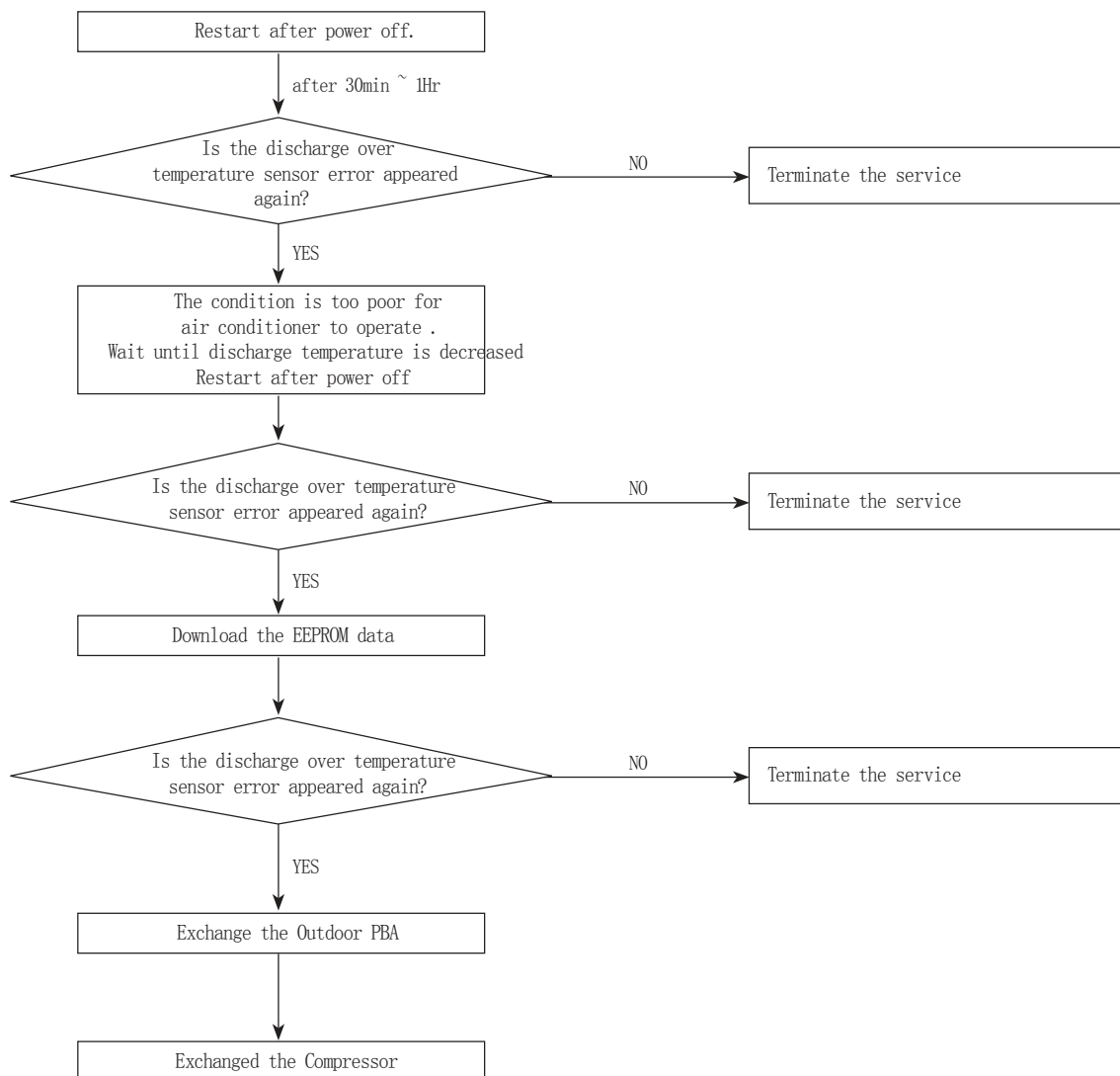

10-2-10 Outdoor Fan motor error

Indoor display

3-LED DISPLAY			7-SEG DISPLAY	DESCRIPTION
LED1	LED2	LED3	E458	Outdoor fan error
◎	○	◎		

Outdoor display

●	○	○	Outdoor fan error
---	---	---	-------------------

● LED ON ◎ LED BLINKING ○ LED OFF

1. Checklist :

- 1) Are the input power voltage and the power connection correct?
- 2) Is the motor wire connected to the outdoor PBA correctly?
- 3) Is there no assembly error or non-assembly in the terminal of motor wire connector?
- 4) Is there no obstacle at the surrounding of motor and propeller?

2. Troubleshooting procedure

MODEL	"A"
ALL	CN901

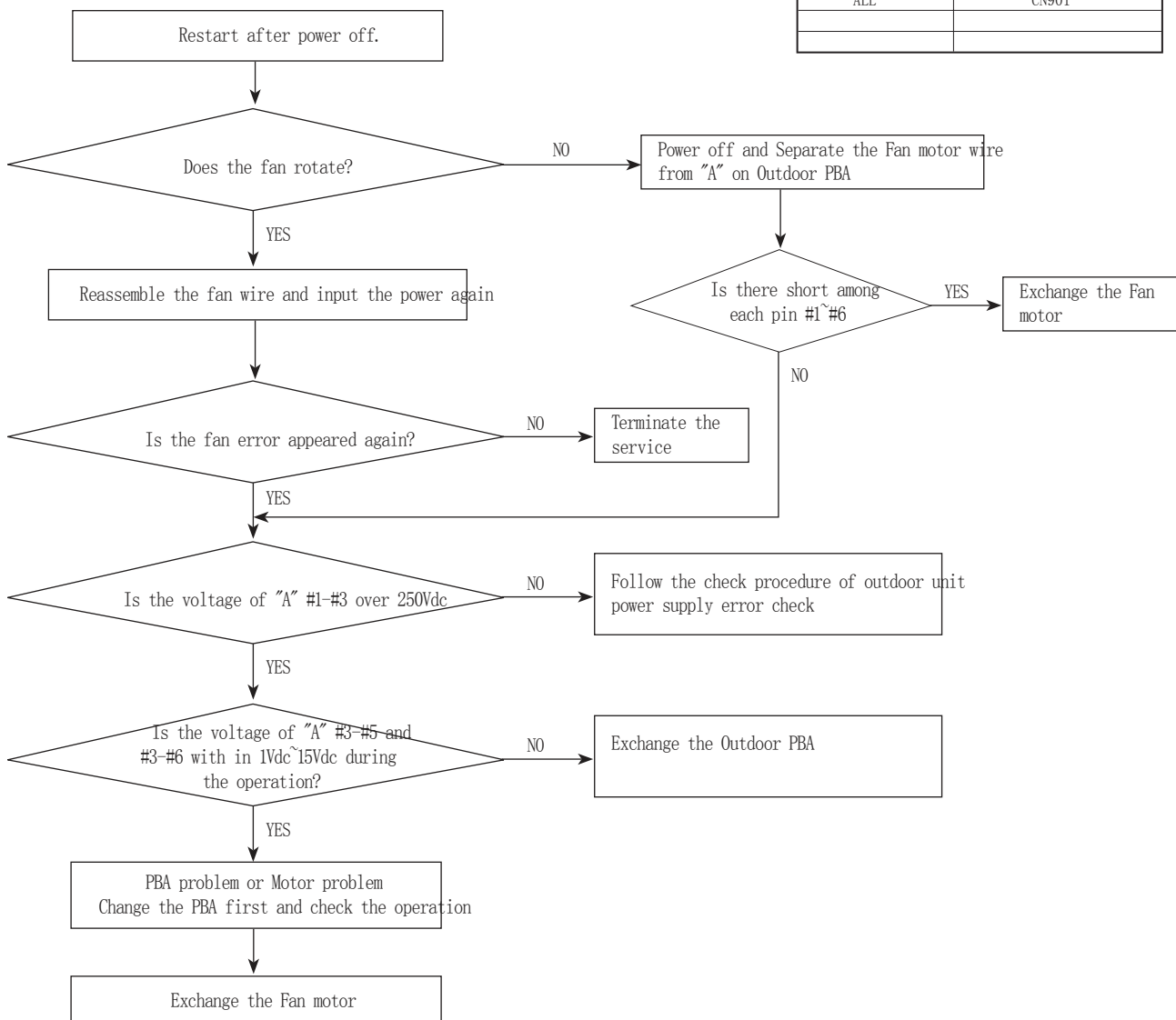

10-2-11 Compressor starting error

Indoor display

3-LED DISPLAY			7-SEG DISPLAY	DESCRIPTION
LED1	LED2	LED3	E461	Comp starting error
◎	○	◎		

Outdoor display

○	◎	○	Comp starting error
---	---	---	---------------------

● LED ON ◎ LED BLINKING ○ LED OFF

1. Checklist :

- 1) Is the connection of cable for the compressor?
- 2) Is the compressor wire is connected clockwise? U(RED)-V(BLU)-W(YEL)
- 3) Is the interphase resistance of compressor normal?

2. Troubleshooting procedure

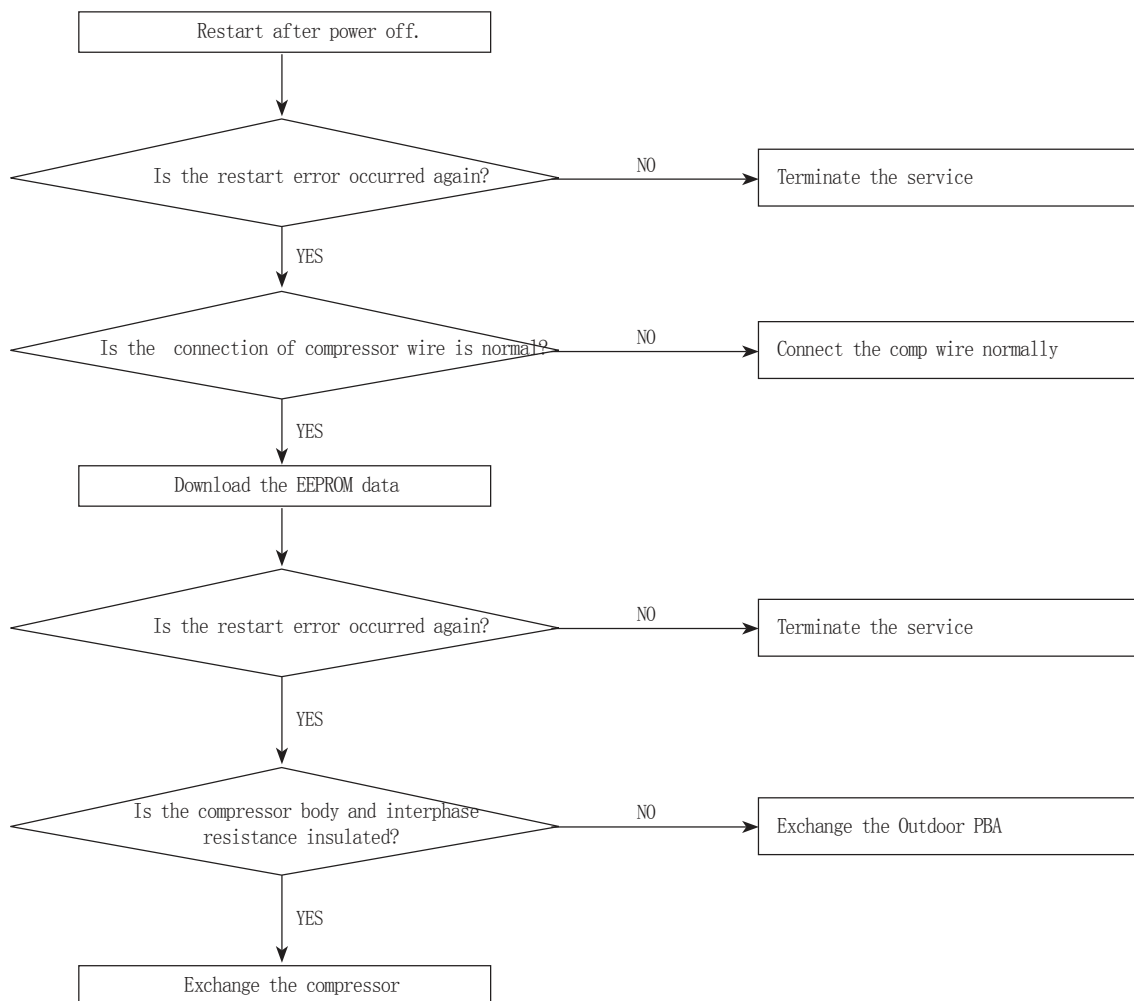

10-2-12 Compressor wire missing error/rotation error

Indoor display

3-LED DISPLAY			7-SEG DISPLAY	DESCRIPTION
LED1	LED2	LED3	E467	Compressor wire missing error/rotation error
◎	○	◎		

Outdoor display

●	○	●	Compressor wire missing error/rotation error
---	---	---	--

● LED ON ◎ LED BLINKING ○ LED OFF

1. Checklist :

- 1) Is the connection of cable for the compressor?
- 2) Is the compressor wire is connected clockwise? U(RED)-V(BLU)-W(YEL)
- 3) Is the interphase resistance of compressor normal?

2. Troubleshooting procedure

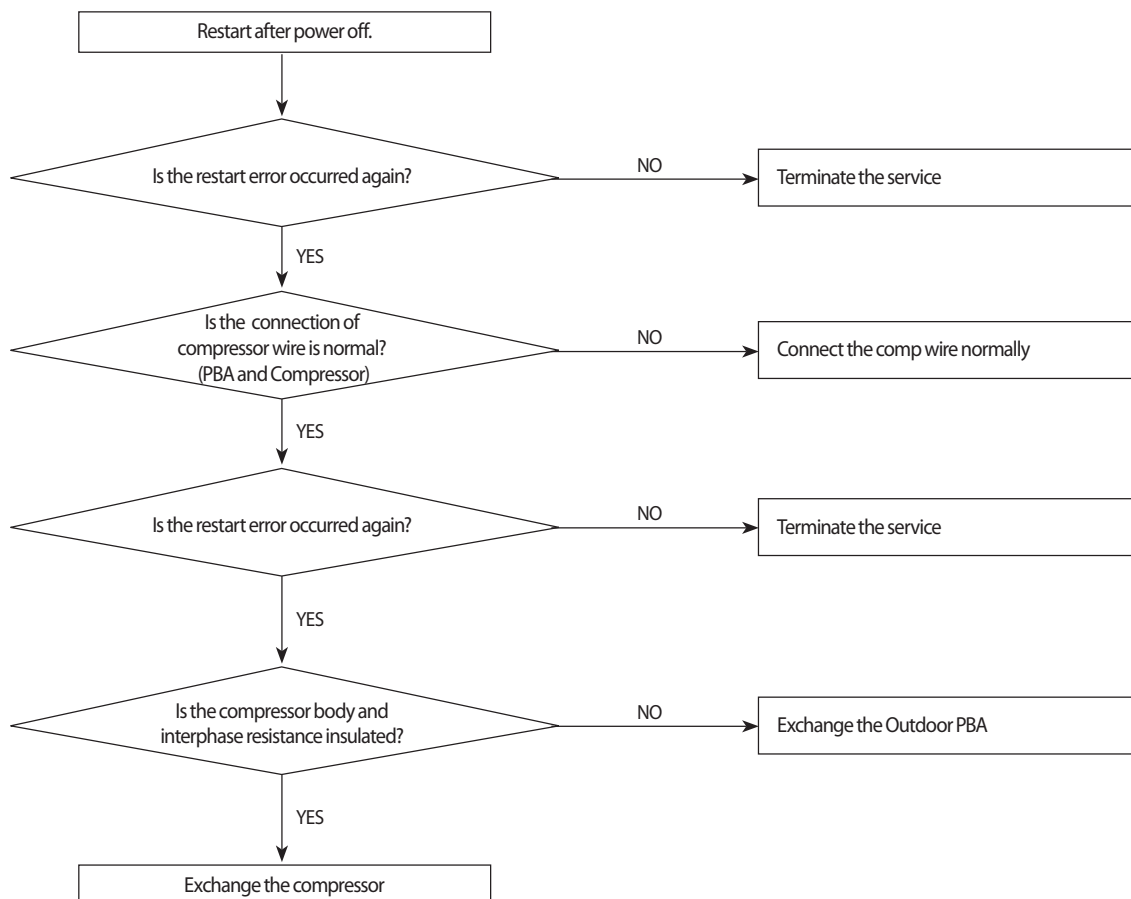

10-2-13 O.C(Over Current) error

Indoor display

3-LED DISPLAY			7-SEG DISPLAY	DESCRIPTION
LED1	LED2	LED3	E464	IPM Over Current(O.C) Error
⊙	○	⊙		

Outdoor display

○	○	⊙	IPM Over Current(O.C) Error
---	---	---	-----------------------------

● LED ON ⊙ LED BLINKING ○ LED OFF

1. Checklist :

- 1) Is the IPM Shunt resistance value correct? Check the resistor is opened
- 2) Is the condition of surrounding temperature abnormal overload?
- 3) Is there any problem as like the temperature sensor separation or measurement value error?
- 4) Is the interphase resistance of compressor normal?

2. Troubleshooting procedure

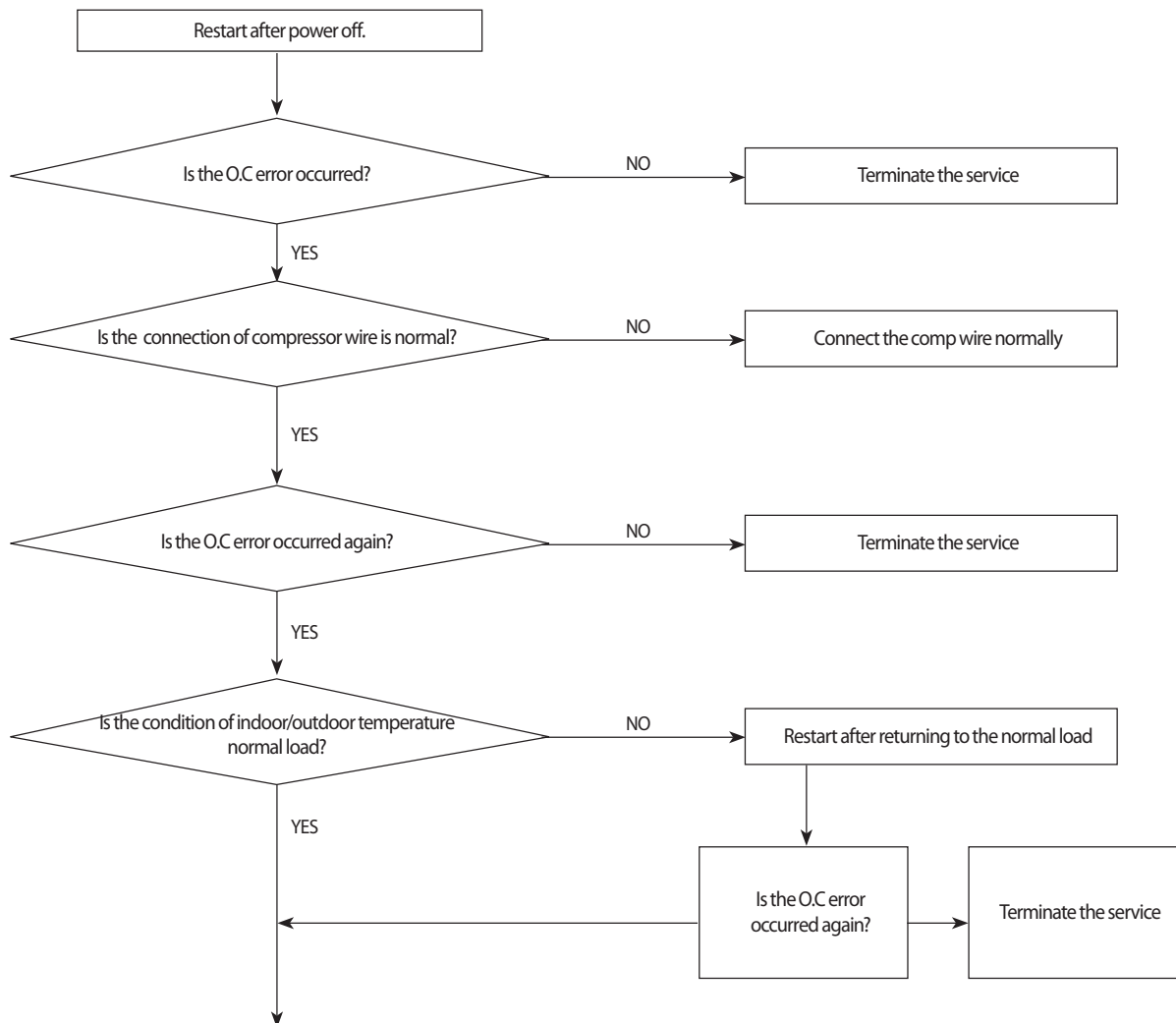

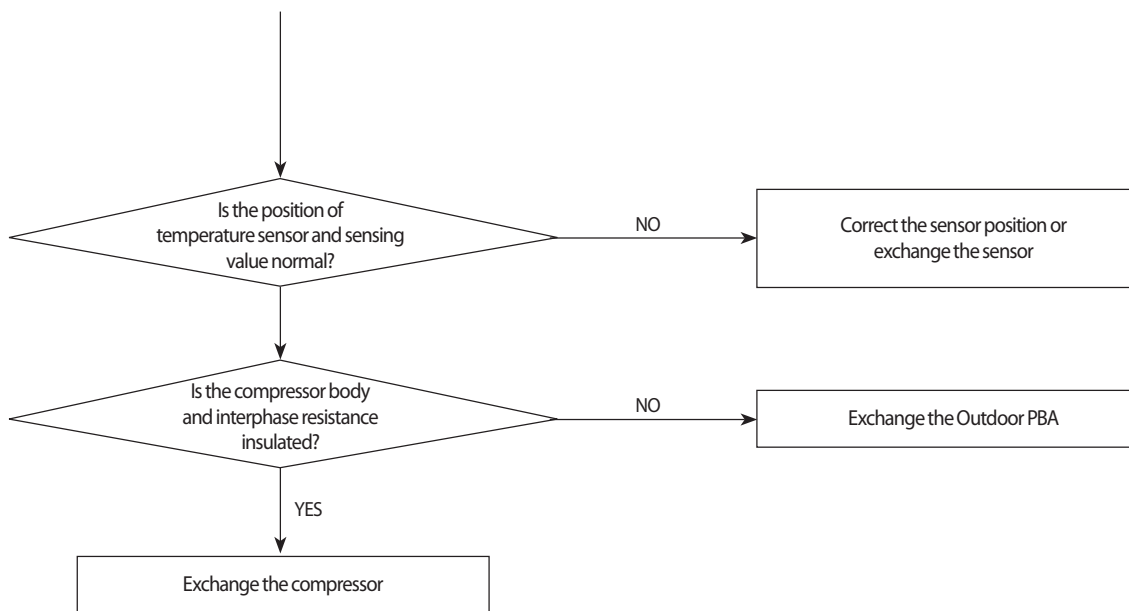

10-2-14 DC_link voltage sensor error

Indoor display

3-LED DISPLAY			7-SEG DISPLAY	DESCRIPTION
LED1	LED2	LED3	E469	DC_link voltage sensor error
⊙	○	⊙		

Outdoor display

●	⊙	○	DC_link voltage sensor error
---	---	---	------------------------------

● LED ON ⊙ LED BLINKING ○ LED OFF

1. Checklist :

- 1) Is the input voltage of outdoor terminal block is normal?
- 2) Is the reactor wire connected?
- 3) Is the DC_link capacitor("A") assembled in accordance the specification? (Outdoor PBA)
- 4) Is the DC_link resistor("B") value is normal? (Outdoor PBA)

2. Troubleshooting procedure

MODEL	"A"	"B"
DB92-02866*	CE101, CE102, CE103	R101
DB92-02867*	CE053, CE054, CE055, CE056	R062

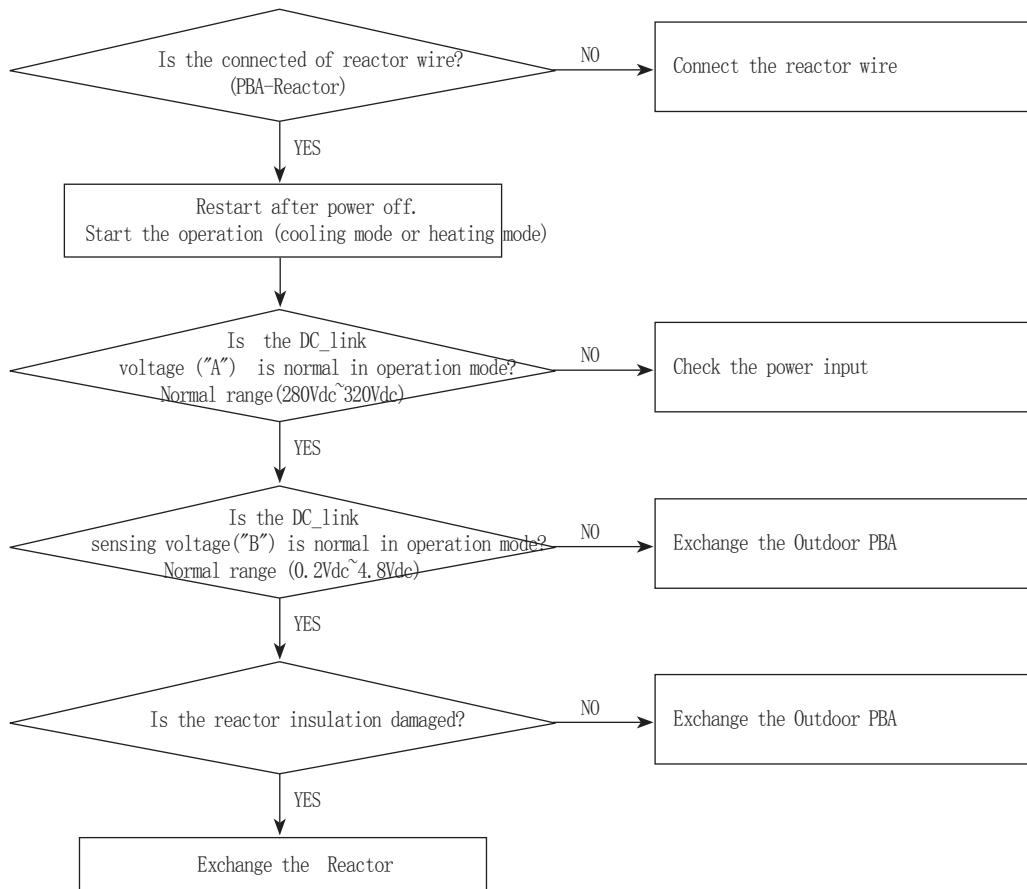

10-2-15 DC_link voltage sensor error

Indoor display

3-LED DISPLAY			7-SEG DISPLAY	DESCRIPTION
LED1	LED2	LED3	E488	AC Input Voltage Sensor Error
⊙	○	⊙		

Outdoor display

●	⊙	⊙	AC Input Voltage Sensor Error
---	---	---	-------------------------------

● LED ON ⊙ LED BLINKING ○ LED OFF

1. Checklist :

- 1) Is the input voltage of outdoor terminal block is normal?
- 2) Is the reactor wire connected?
- 3) Is the PFC resistor("A") value is normal? (Outdoor PBA)

2. Troubleshooting procedure

MODEL	"A"	"B"
DB92-02866*/2867*	R105, R106, R107, R108	R105

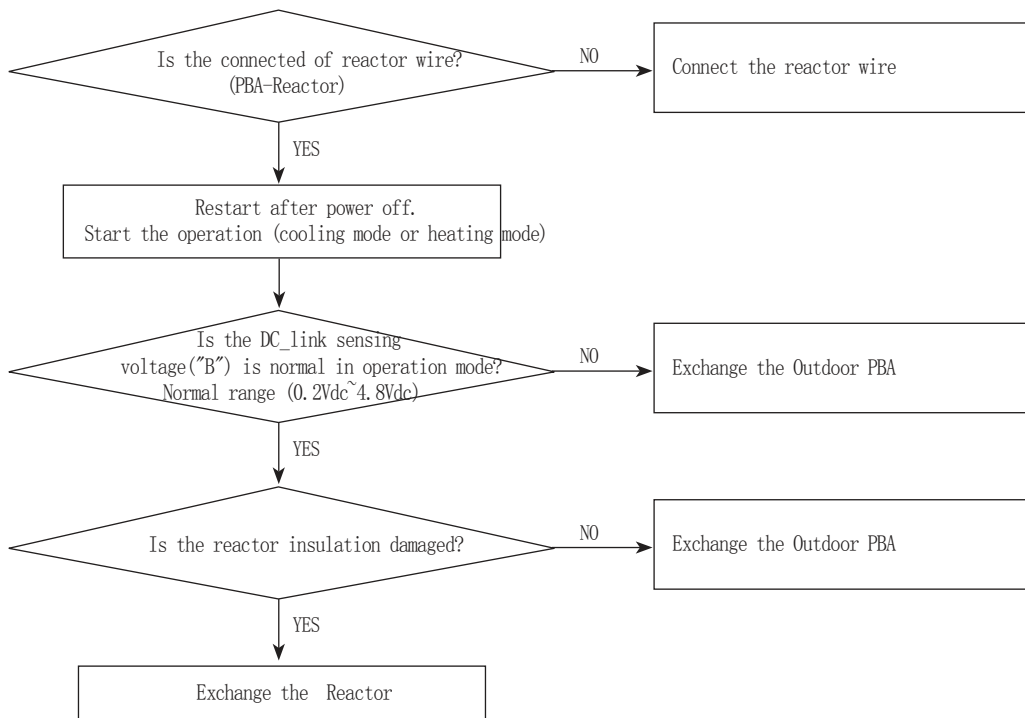

10-2-16 DC_link voltage under/over error, H/W DC-link Over voltage protection error/PFC over load

Indoor display

3-LED DISPLAY			7-SEG DISPLAY	DESCRIPTION
LED1	LED2	LED3		
⊙	○	⊙	E466	DC-Link voltage under/over error
			E483	Over Voltage Protection Error
			E484	PFC over load

Outdoor display

LED1	LED2	LED3	DESCRIPTION
○	●	⊙	DC-Link voltage under/over error
			PFC over load
			Over Voltage Protection Error

● LED ON ⊙ LED BLINKING ○ LED OFF

1. Checklist :

- 1) Is the input voltage of outdoor terminal block is normal?
- 2) Is the input voltage is higher than 300Vac?
- 3) Is the reactor wire connected?
- 4) Is the DC_link capacitor("A") assembled in accordance the specification? (Outdoor PBA)
- 5) Is the DC_link resistor("B") value is normal? (Outdoor PBA)
- 6) Is the PFC resistor("C") value is normal? (Outdoor PBA)

MODEL	"A"	"B"
DB92-02866*	CE101, CE102, CE103	R101, R102, R103, R104
DB92-02867*	CE053, CE054, CE055, CE056	R059, R060, R061, R062
MODEL	"C"	"D"
DB92-02866*/2867*	R105, R106, R107, R108	R105

2. Troubleshooting procedure

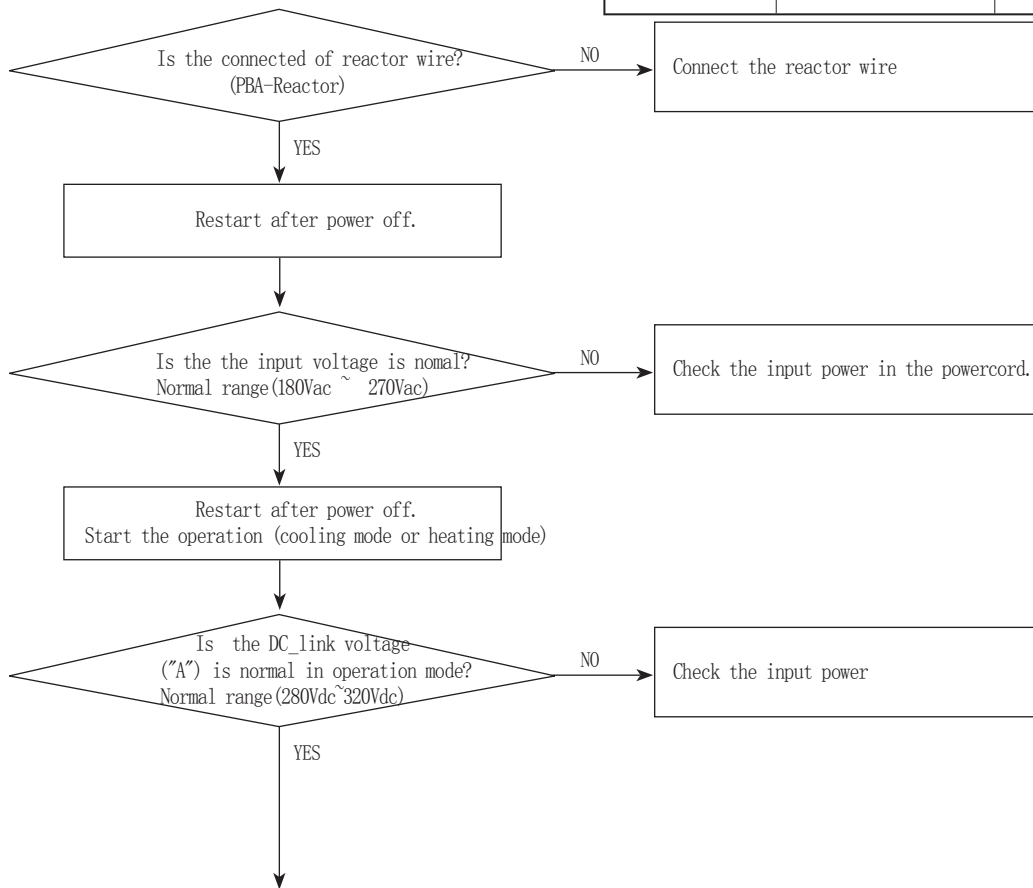

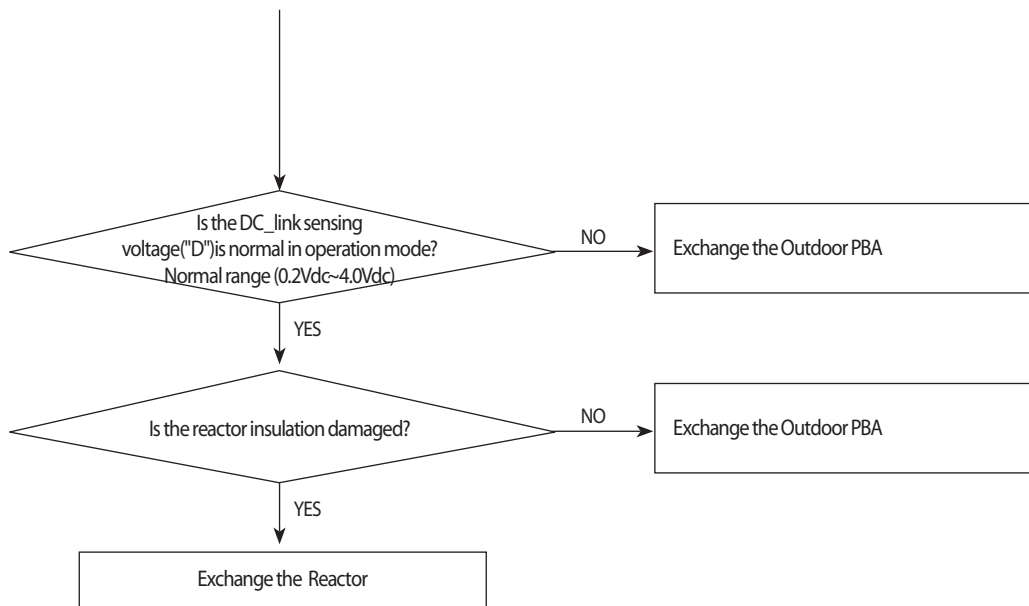

10-2-17 I_trip error, PFC over current

Indoor display

3-LED DISPLAY			7-SEG DISPLAY	DESCRIPTION
LED1	LED2	LED3	E462	AC Input I_Limit Trip Error
⊙	○	⊙		

Outdoor display

●	⊙	●	AC Input I_Limit Trip Error
---	---	---	-----------------------------

● LED ON ⊙ LED BLINKING ○ LED OFF

1. Checklist :

- 1) Is the PFC Shunt("A") resistance value correct? Check the resistor is opened
- 2) Is the condition of surrounding temperature abnormal overload?
- 3) Is there any problem as like the temperature sensor separation or measurement value error?
- 4) Is the interphase resistance of compressor normal?

2. Troubleshooting procedure

MODEL	"A"
DB92-02866*	R410, R411, R412
DB92-02867*	R408, R409, R410

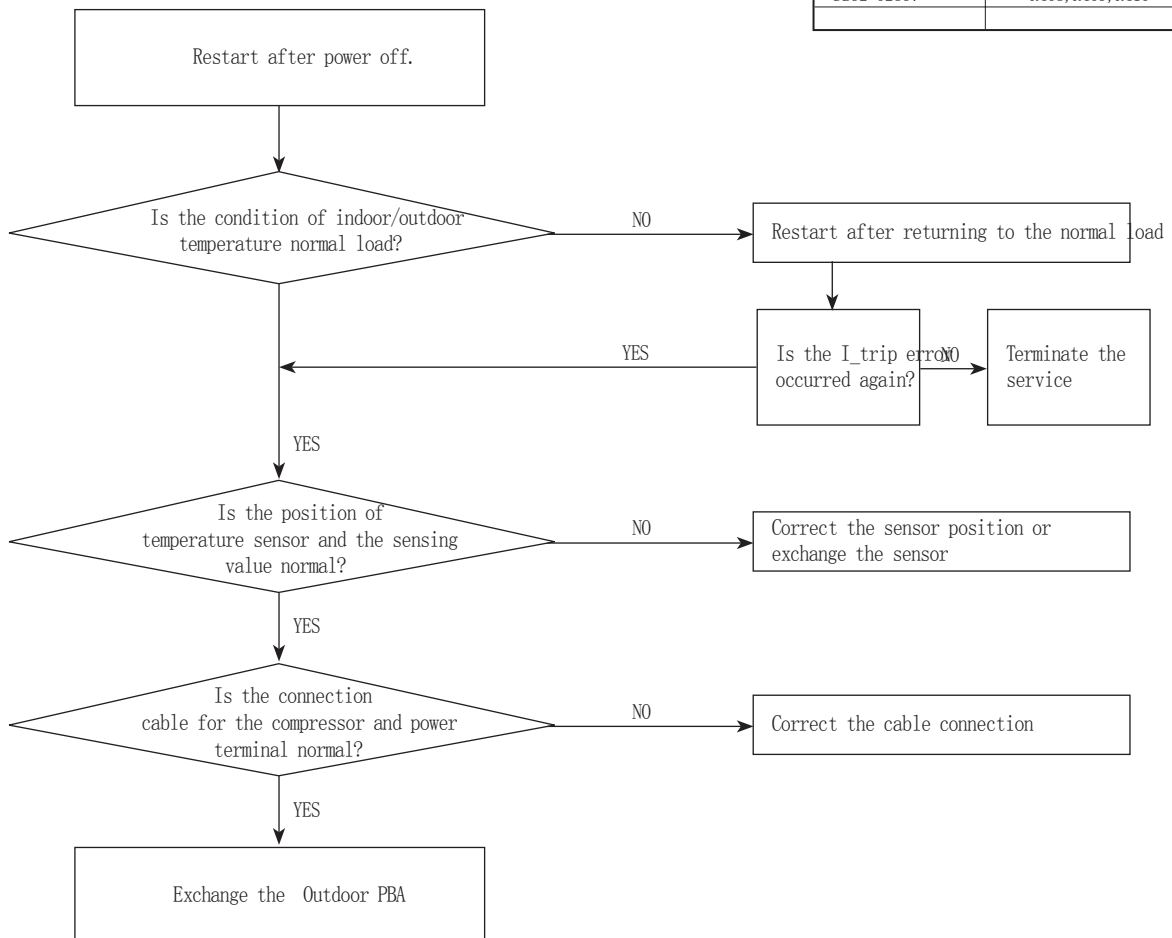

10-2-18 Current sensor error/Input current sensor error

Indoor display

3-LED DISPLAY			7-SEG DISPLAY	DESCRIPTION
LED1	LED2	LED3		
⊙	○	⊙	E462	AC Input I_Limit Trip Error

Outdoor display

●	⊙	○	●	Current sensor error
⊙	⊙	●		Input current sensor error

● LED ON ⊙ LED BLINKING ○ LED OFF

1. Checklist :

- 1) Is the PFC Shunt("A") resistance value correct? Check the resistor is opened
- 2) Is the IPM Shunt("B") resistance value correct? Check the resistor is opened
- 3) Is there no short or open around "C"?

2. Troubleshooting procedure

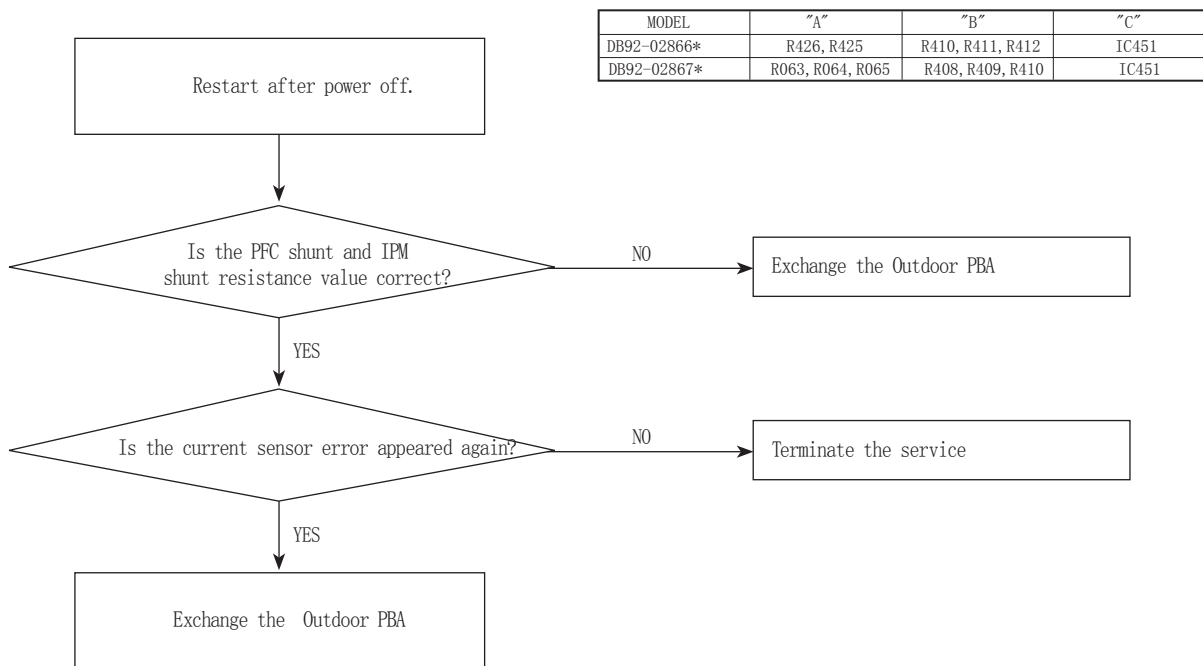

10-2-19 Heatsink sensor error/Heatsink over heat

Indoor display

3-LED DISPLAY			7-SEG DISPLAY	DESCRIPTION
LED1	LED2	LED3		
⊙	○	⊙	E474	Heatsink sensor error
			E500	Heatsink Over Temperature Error

Outdoor display

⊙	⊙	●	Heatsink sensor error
⊙	●	○	Heatsink Over Temperature Error

● LED ON ⊙ LED BLINKING ○ LED OFF

1. Checklist :

- 1) Are there screws assembly in PBA-heatsink?
- 2) Is the gap PBA-heatsink
- 3) Is the fan operation normal?
- 4) Is the cover assembly in control-box normal?

2. Troubleshooting procedure

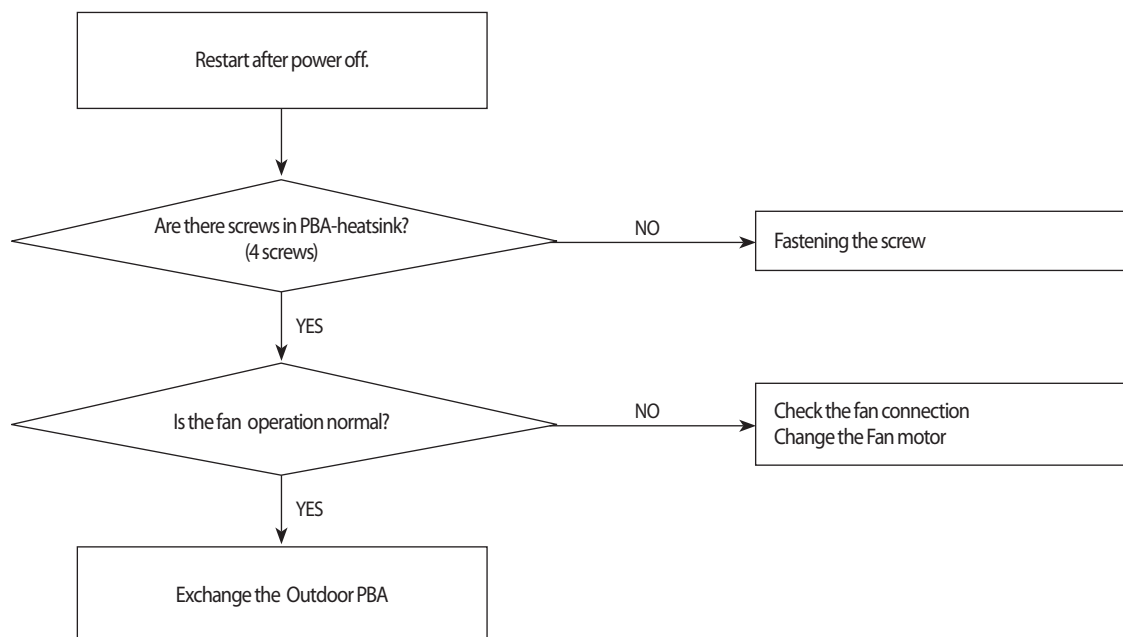

10-2-20 Comp Vlimit error

Indoor display

3-LED DISPLAY			7-SEG DISPLAY	DESCRIPTION
LED1	LED2	LED3		
◎	○	◎	E465	Comp V_limit/I_limit Error

Outdoor display

◎	●	○	Comp V_limit/I_limit Error
---	---	---	----------------------------

● LED ON ◎ LED BLINKING ○ LED OFF

1. Checklist :

- 1) Is the IPM Shunt("A") resistance value correct? Check the resistor is opened
- 2) Is the condition of surrounding temperature abnormal overload?
- 3) Is there any problem as like the temperature sensor separation or measurement value error?
- 4) Is the interphase resistance of compressor normal?

2. Troubleshooting procedure

MODEL	"A"
DB92-02866*	R410, R411, R412
DB92-02867*	R408, R409, R410

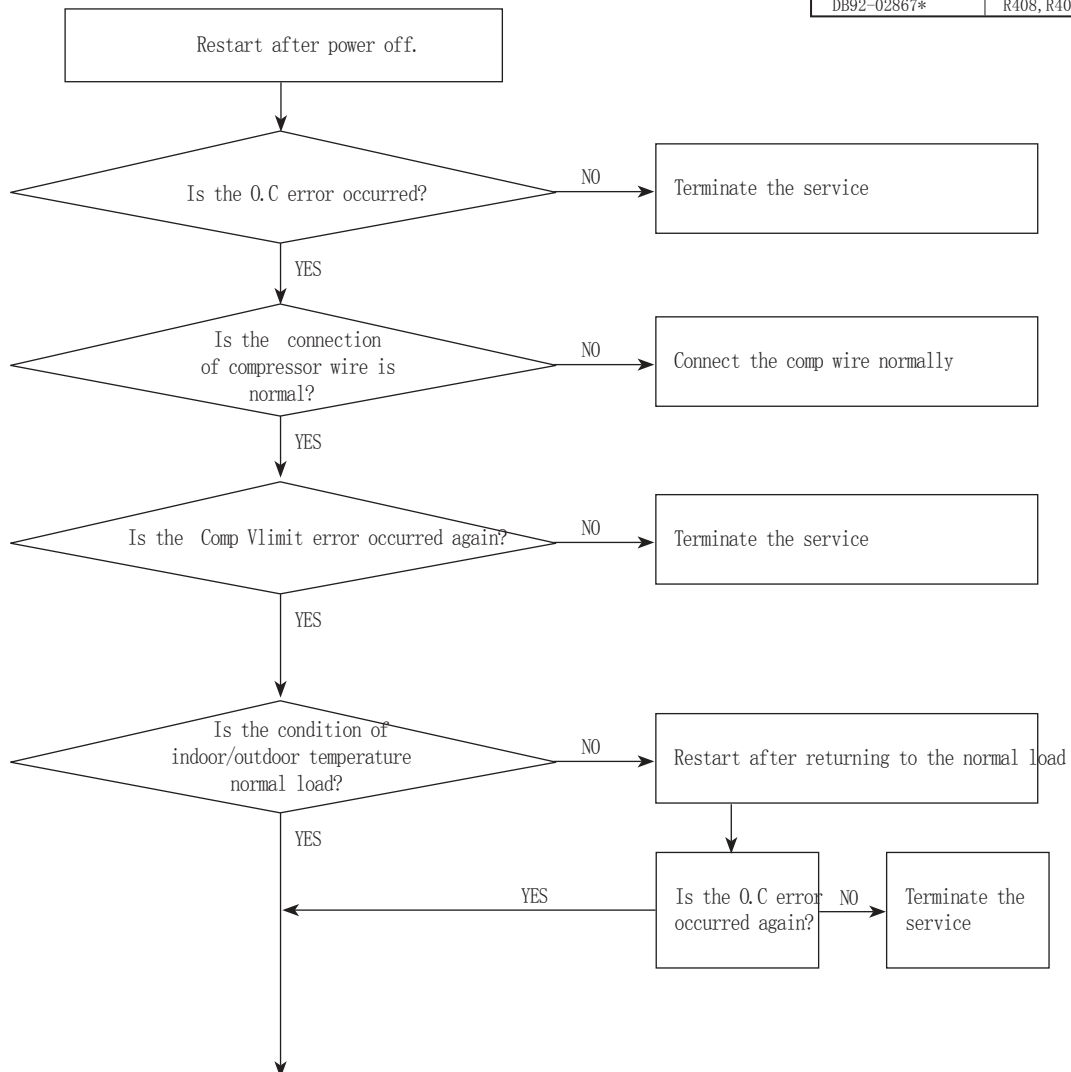

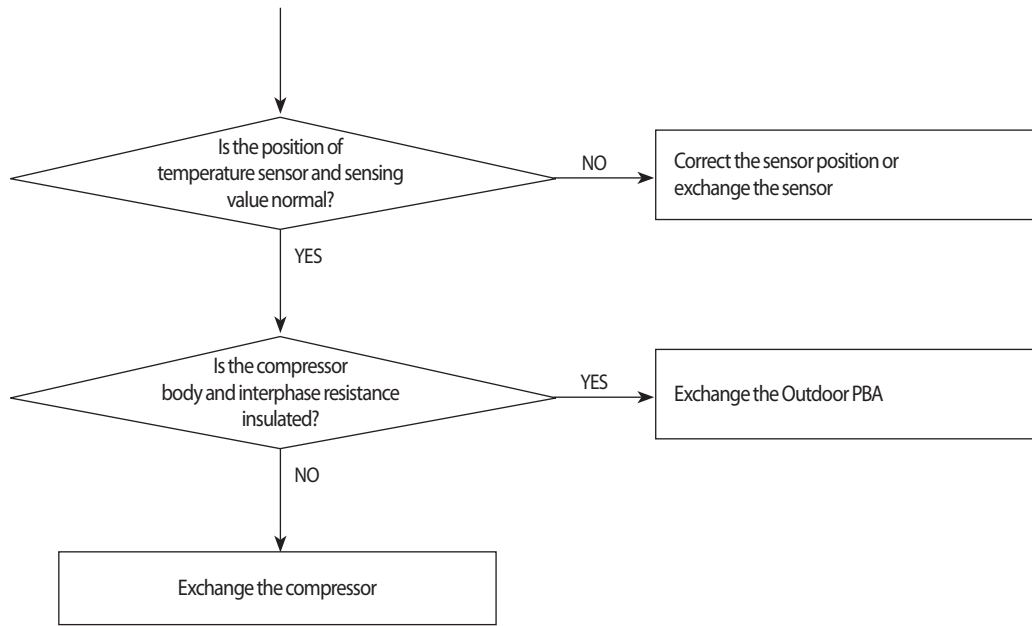

10-2-21 EEPROM error/OTP error

Indoor display

3-LED DISPLAY			7-SEG DISPLAY	DESCRIPTION
LED1	LED2	LED3		
◎	○	◎	E470	EEPROM Data Error (no data)
			E471	OTP errorEEPROM Data Error (Main Micom↔Inv Micom)

Outdoor display

○	●	○	EEPROM Data Error (no data)
●	○	◎	OTP errorEEPROM Data Error (Main Micom↔Inv Micom)

● LED ON ◎ LED BLINKING ○ LED OFF

1. Checklist :

- 1) Is there a short around micom?
- 2) Is there a short around "A"?
- 3) Did you download or insert EEPROM IC, after changing outdoor PBA?

2. Troubleshooting procedure

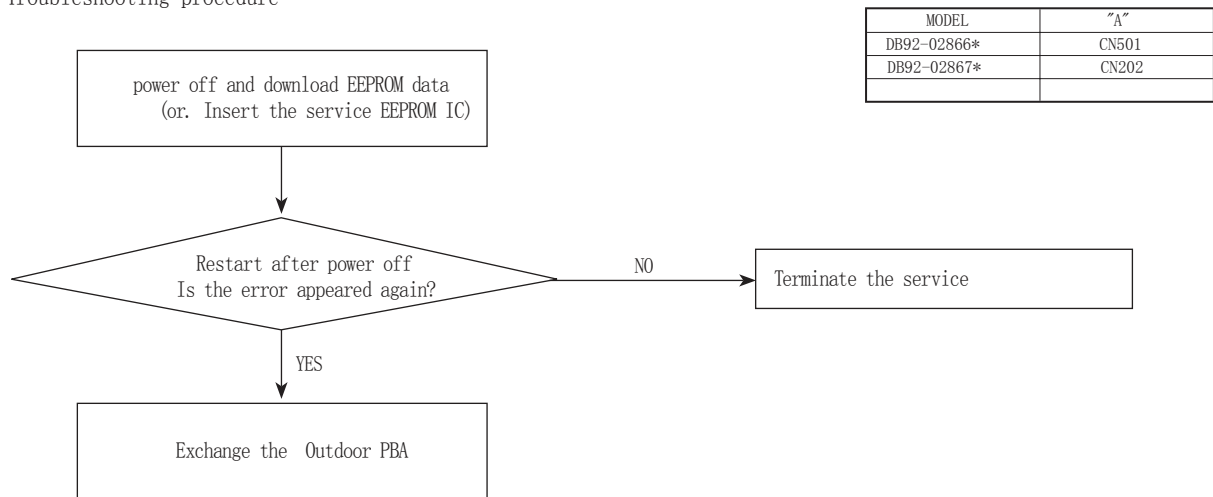

10-2-22 Operation condition secession error

Indoor display

3-LED DISPLAY			7-SEG DISPLAY	DESCRIPTION
LED1	LED2	LED3		
◎	○	◎	E440	Prohibit Operation Condition Error (Heating)
			E441	Prohibit Operation Condition Error (Cooling)

Outdoor display

●	◎	○	Operation condition secession
---	---	---	-------------------------------

● LED ON ◎ LED BLINKING ○ LED OFF

1. Checklist :

- 1) Check the temperature around the outdoor unit.

2. Troubleshooting procedure

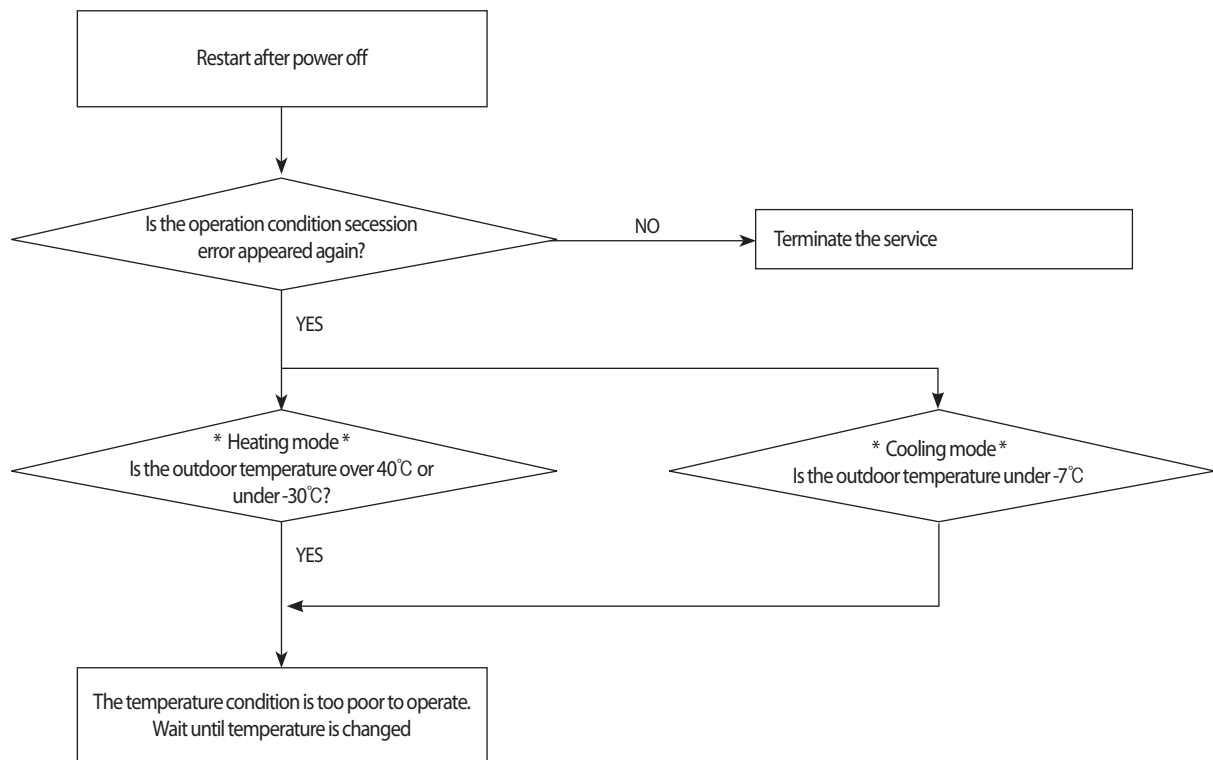

10-2-23 Gas leak error

Indoor display

3-LED DISPLAY			7-SEG DISPLAY	DESCRIPTION
LED1	LED2	LED3		
◎	○	◎	E554	GAS Leak error

Outdoor display

●	●	○	GAS Leak error
---	---	---	----------------

● LED ON ◎ LED BLINKING ○ LED OFF

1. Checklist :

- 1) Is the position of indoor Eva_in sensor normal?
- 2) Check the pipe crack
- 3) Check the EEV valve connection("A") in Outdoor unit
- 4) Check the refrigerant was charged

2. Troubleshooting procedure

MODEL	"A"
DB92-02866*	CN701
DB92-02867*	CN701

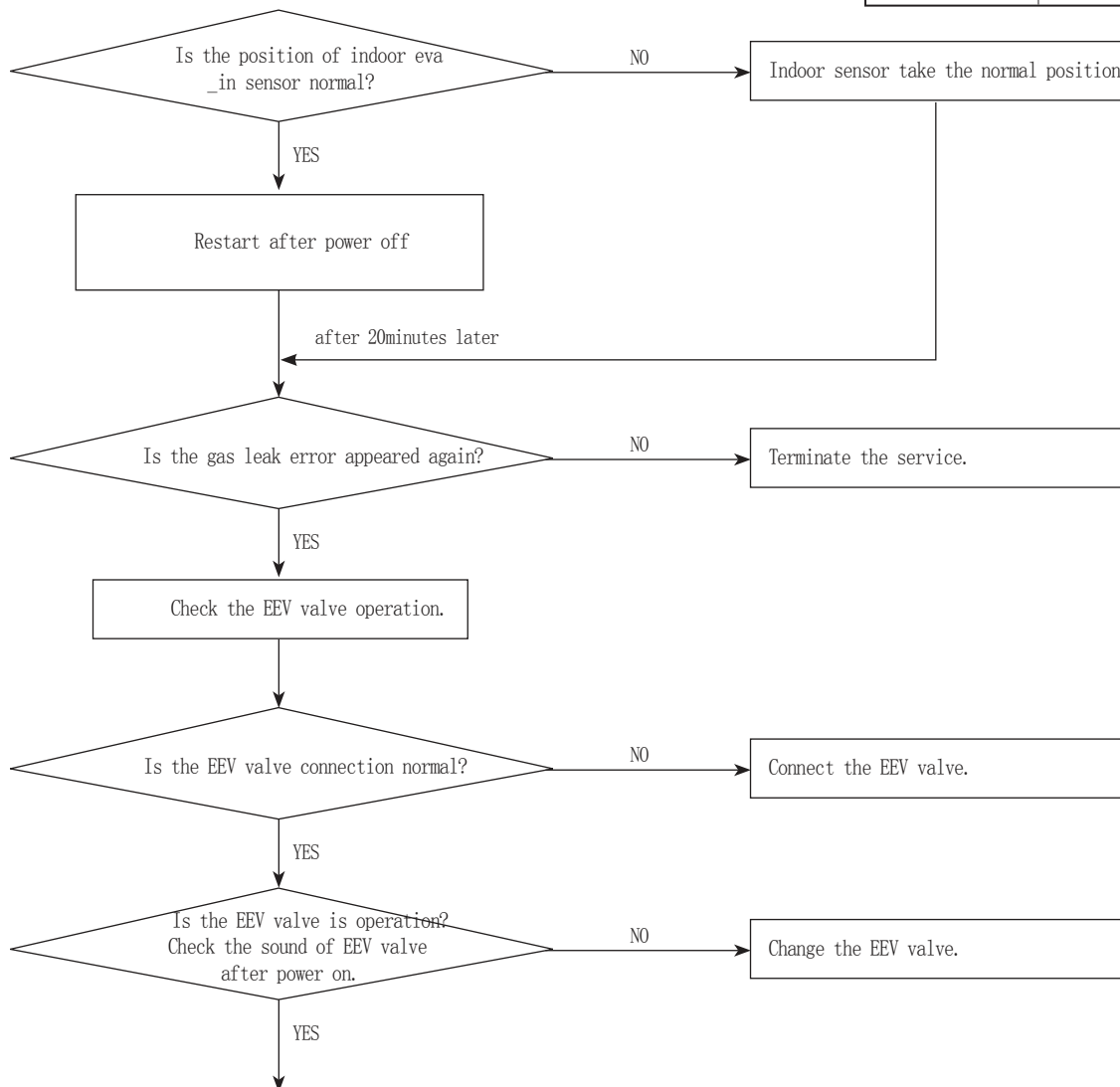

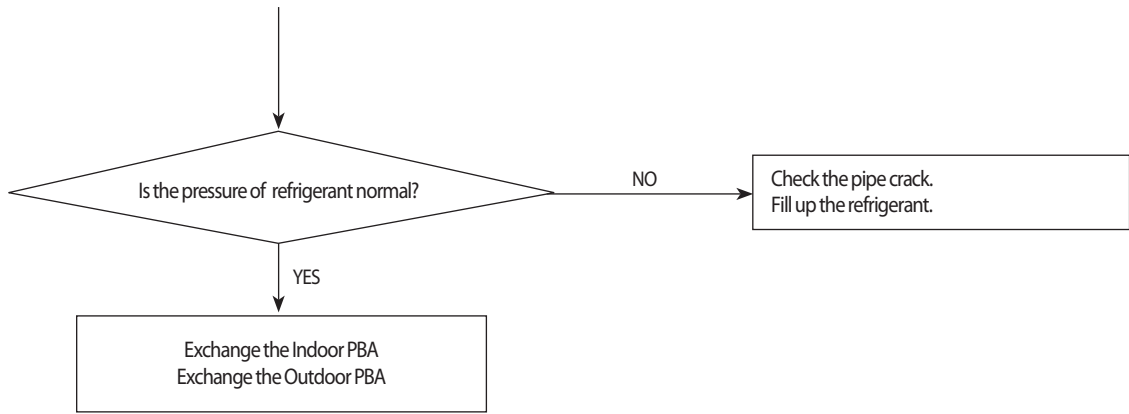

102-24 No power outdoor (Initial Diagnosis) (Not displayed)

1. Checklist :

- 1) Is input power normal?
- 2) Is AC power linked correctly? (L, N, E)
- 3) Is mis-wiring between communication wire and Power wire?
- 4) Is mis-wiring between Main PBA and SMPS PBA wire?
- 5) Is input voltage of SMPS AC in Main PBA (CN150) normal?
- 6) Is the voltage of SMPS DC in Main PBA (CN151, CN152) normal?

2. Troubleshooting procedure

MODEL
ALL

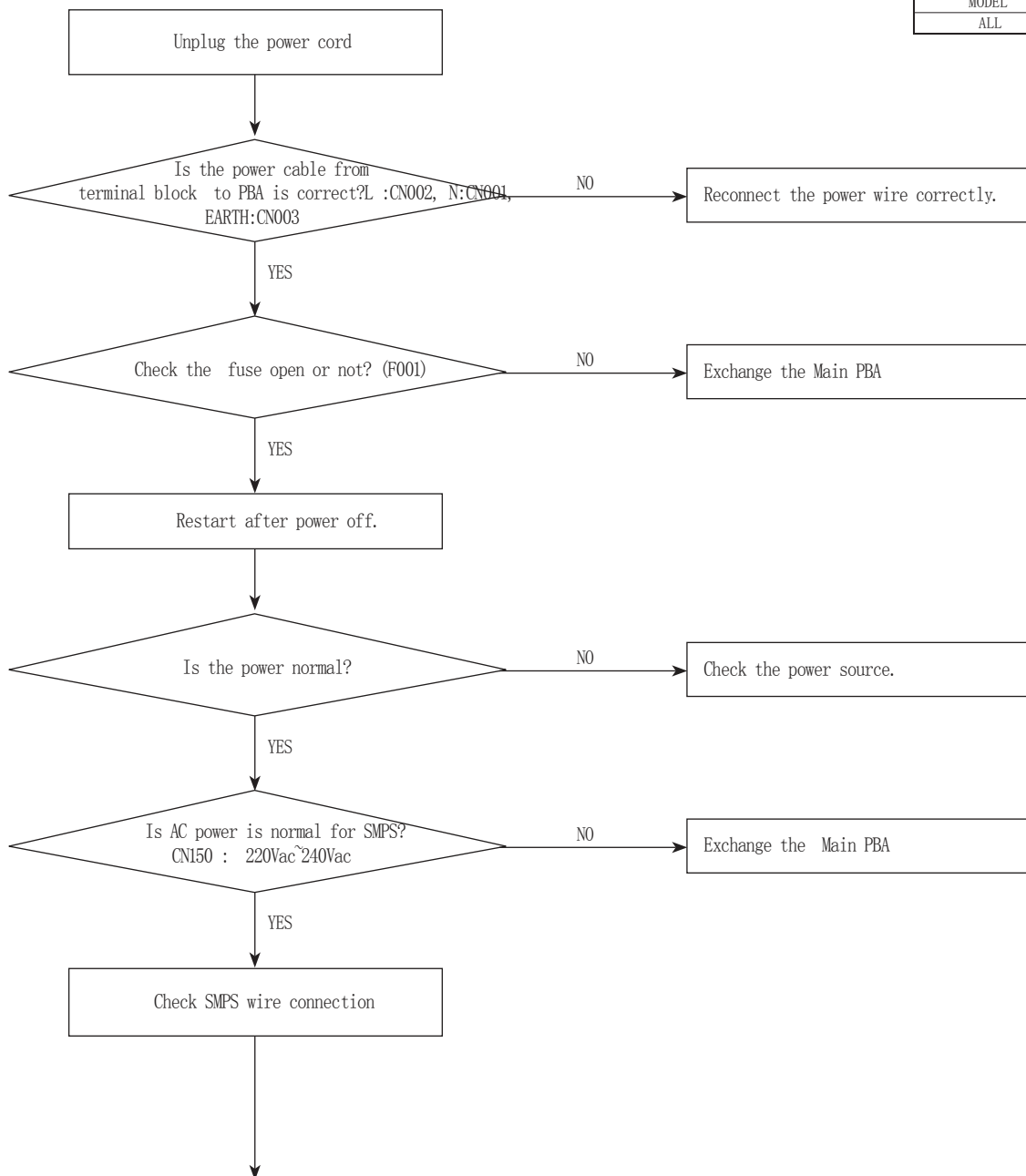

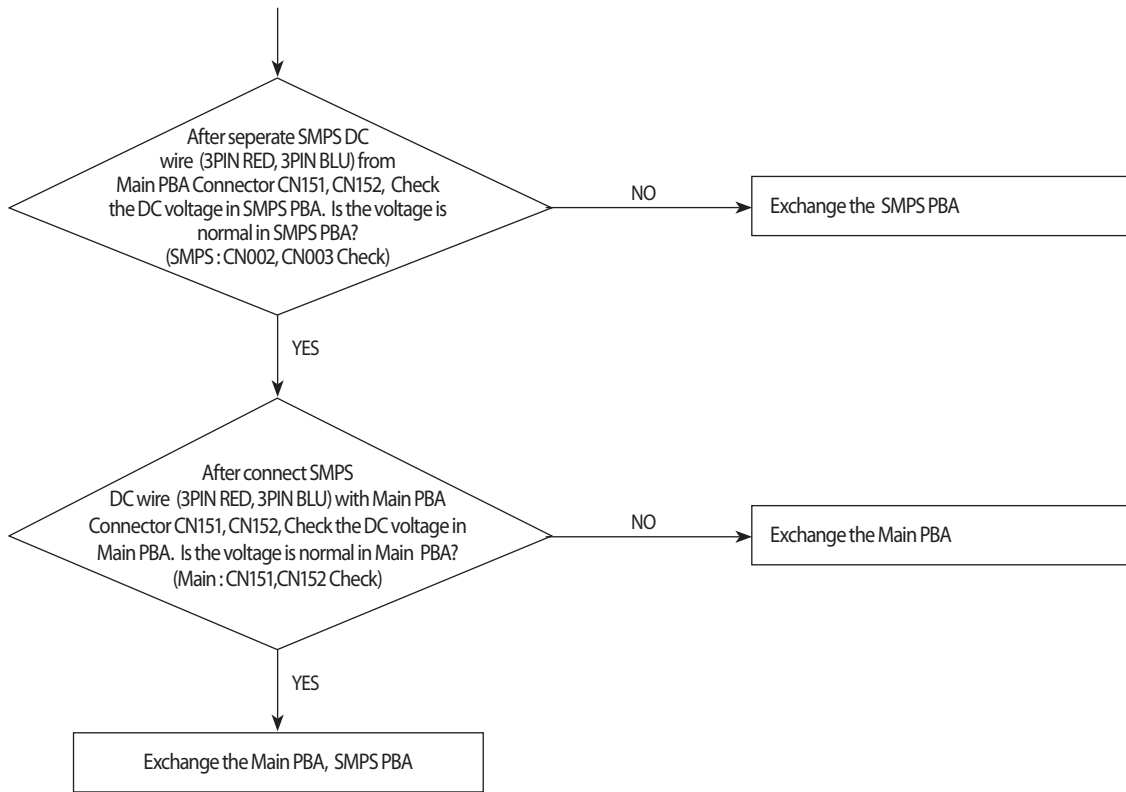

10-2-25 No power outdoor (Initial Diagnosis) (Not displayed)

1. Checklist :

- 1) Is input power normal?
- 2) Is AC power linked correctly? (L, N, E)
- 3) Is mis-wiring between communication wire and Power wire?
- 4) Is input voltage of SMPS DC-link capacitor("A") normal?
- 5) Is the voltage of SMPS DC normal?

2. Troubleshooting procedure

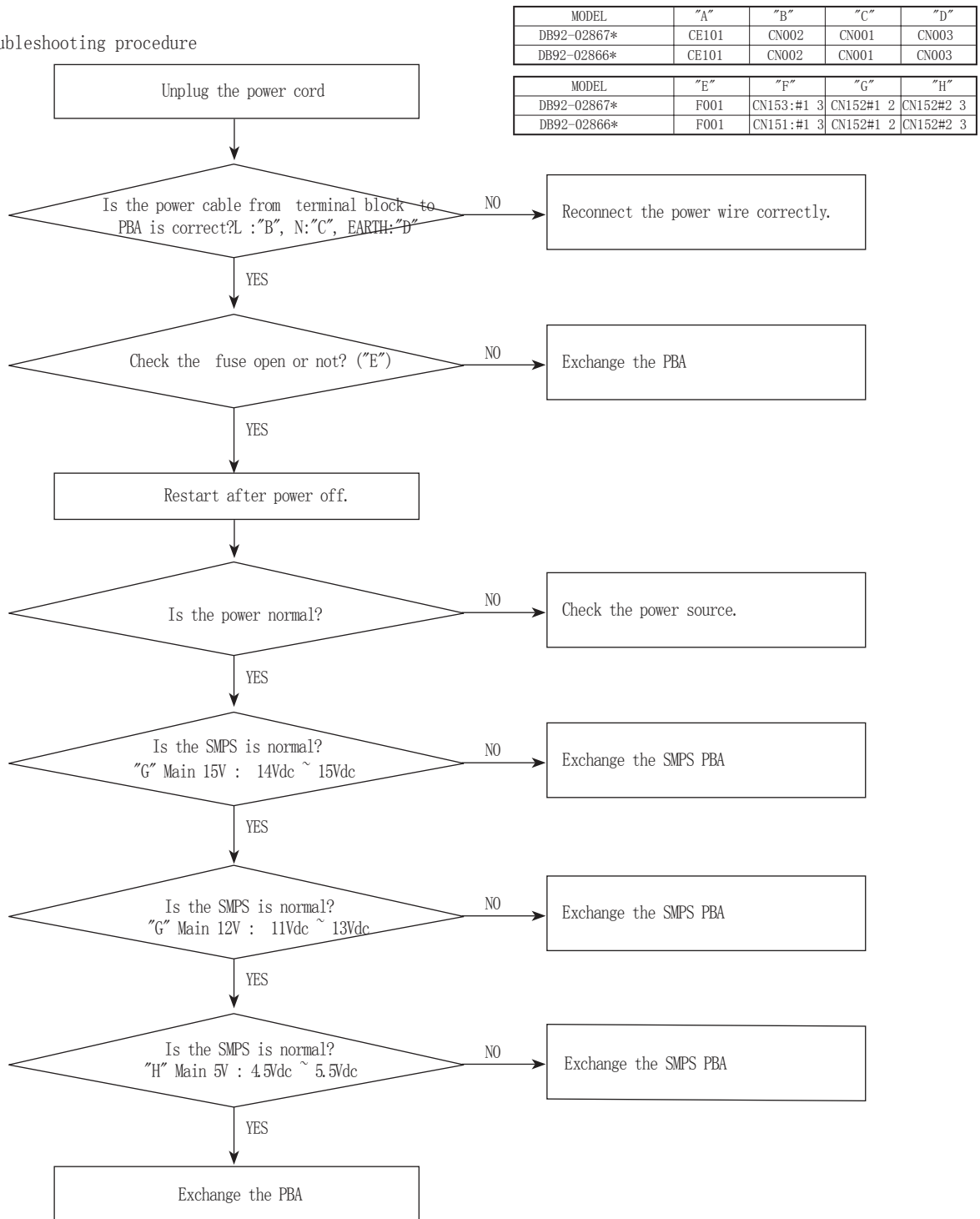

MODEL	"A"	"B"	"C"	"D"
DB92-02867*	CE101	CN002	CN001	CN003
DB92-02866*	CE101	CN002	CN001	CN003

MODEL	"E"	"F"	"G"	"H"
DB92-02867*	F001	CN153:#1 3	CN152#1 2	CN152#2 3
DB92-02866*	F001	CN151:#1 3	CN152#1 2	CN152#2 3

10-2-26 AC zero cross signal error

Indoor display

3-LED DISPLAY			7-SEG DISPLAY	DESCRIPTION
LED1	LED2	LED3		
◎	○	◎	E472	AC zero cross signal error

Outdoor display

●	●	◎	AC zero cross signal error
---	---	---	----------------------------

● LED ON ◎ LED BLINKING ○ LED OFF

1. Checklist :

- 1) Check the power condition at customer's house (Is there any power noise?)
- 2) Have been there power failure?

2. Troubleshooting procedure

MODEL	Error display
DB92-02866*/2867*	0

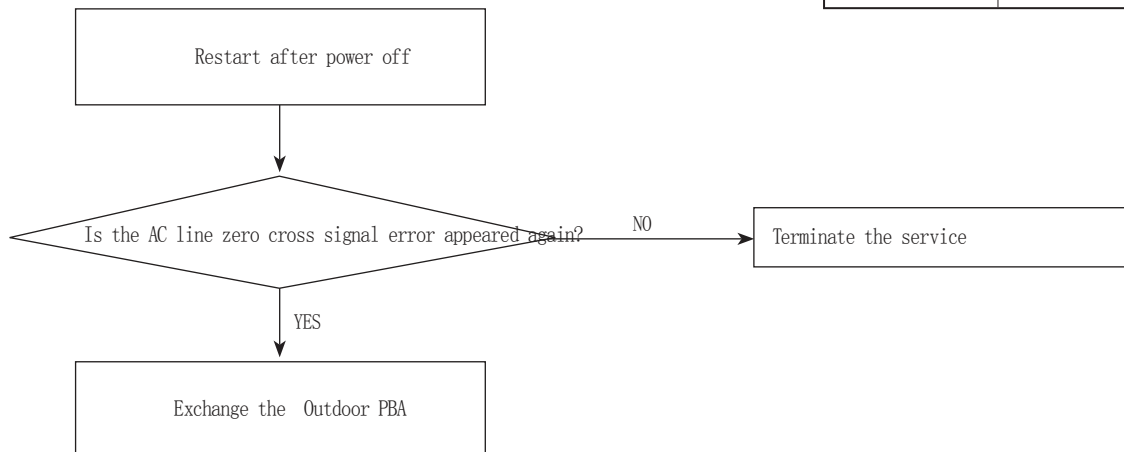

10-2-27 AC zero cross signal error

Indoor display

3-LED DISPLAY			7-SEG DISPLAY	DESCRIPTION
LED1	LED2	LED3		
◎	○	◎	E556	Capacity miss match error

Outdoor display

◎	○	○	Capacity miss match error	
---	---	---	---------------------------	--

● LED ON ◎ LED BLINKING ○ LED OFF

1. Checklist :

- 1) Check the Btu between indoor and outdoor unit
- 2) Check the indoor unit option and outdoor unit EEPROM data

MODEL	Error display
DB92-02866*/2867*	0

2. Troubleshooting procedure

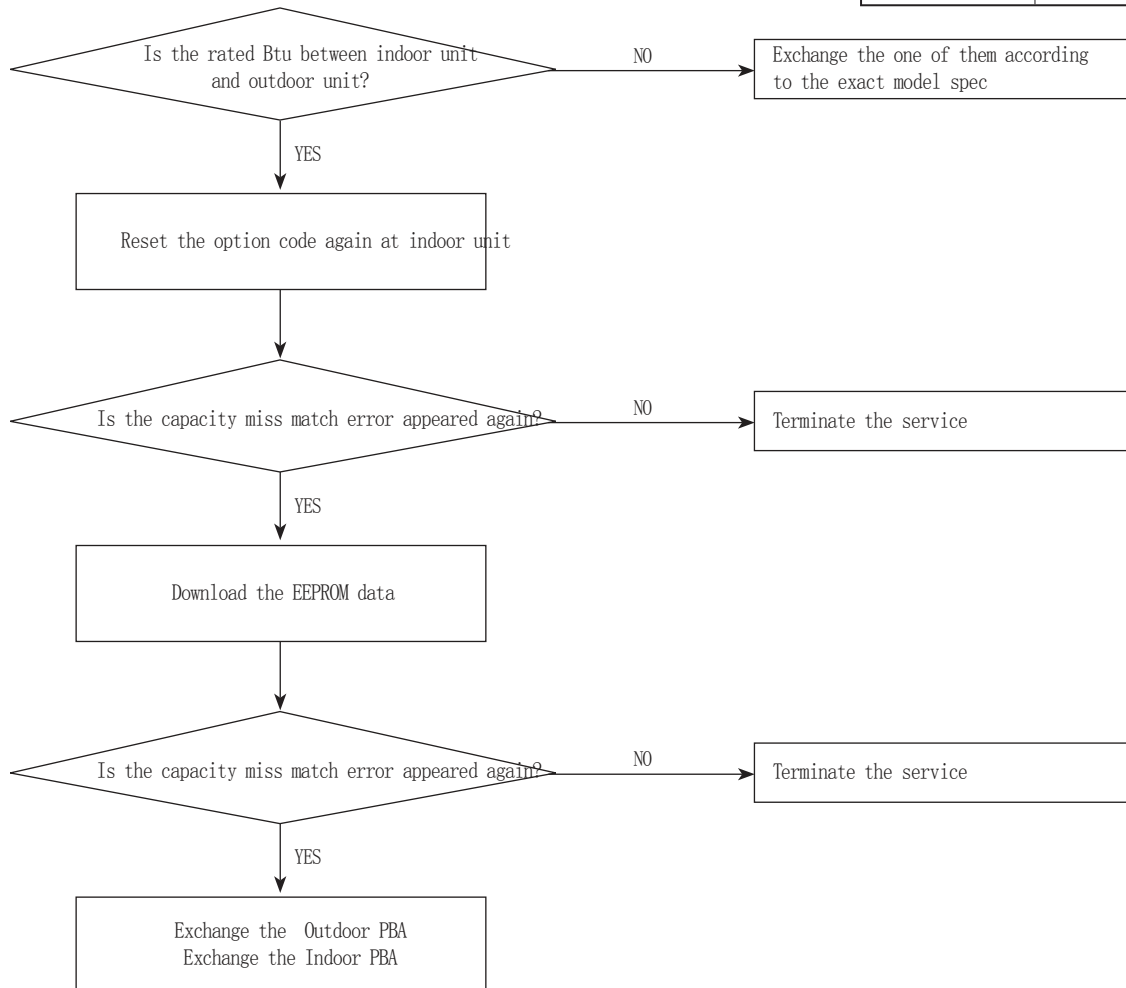

10-2-28 When the remote control is not receiving

1. Checklist :

- 1) Check if the connector was normally assembled.
- 2) Check the battery in remote control
- 3) All the lights out and check again : Change electronic typed to a fluorescent light
- 4) Put the set in operation and check the voltage of display PBA
- 5) Replace the display PBA

10-2-29 EEV or Valve Close error-Self diagnosis

Indoor display

3-LED DISPLAY			7-SEG DISPLAY	DESCRIPTION
LED1	LED2	LED3		
◎	○	◎	E422	EEV or Valve Close error-Self diagnosis

Outdoor display

●	●	○	EEV or Valve Close error-Self diagnosis
---	---	---	---

● LED ON ◎ LED BLINKING ○ LED OFF

1. Checklist :

- 1) Is the position of indoor Eva_in sensor normal?
- 2) Check the pipe crack
- 3) Check the EEV valve connection("A") in Outdoor unit
- 4) Check the refrigerant was charged

MODEL	"A"
DB92-02866*/2867*	CN701

2. Troubleshooting procedure

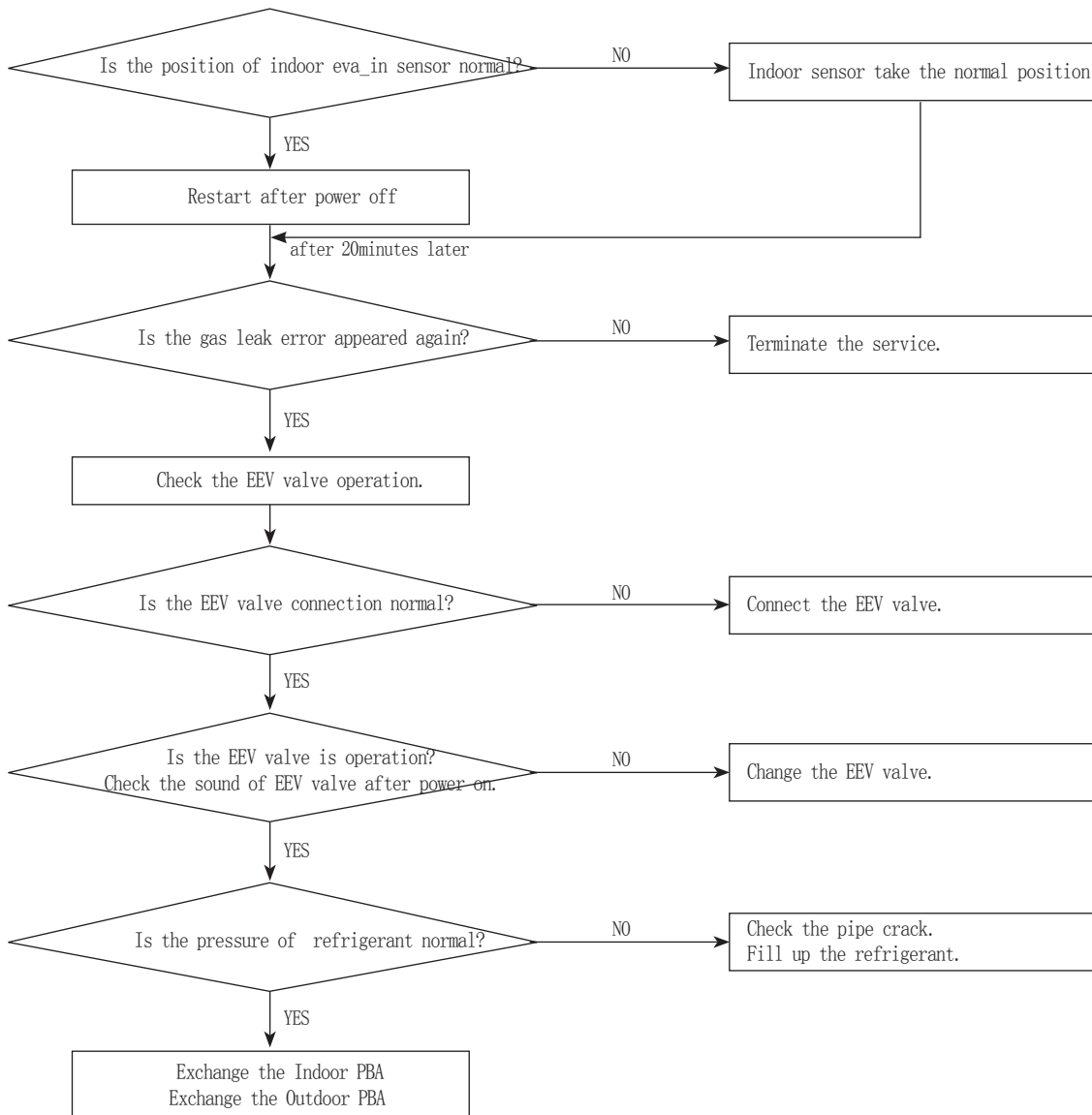

10-2-30 10-3-18 Smart Install error

1. Checklist :

- 1) Check the leakage region.(Use leakage detection liquid or soapy water)
- 2) When leakage region is found from service valve and piping connection flare nut part : After the related measures to check the refrigerant supplements and operation.
- 3) If the leakage region is pipe welding part : Weld leakage region after refrigerant gas release.(Brass parts should only apply)
- 4) If the leakage region is surface area (Heat exchanger or pipe welding region is not) : Replace parts.
- 5) Check the PBA Relay
 - Display of indoor unit : Ensure that the operating pilot lamp has been lighted.
 - Ensure that the Relay input voltage of indoor unit PBA is normally.(If the PBA is defective, replace)

2. Troubleshooting procedure

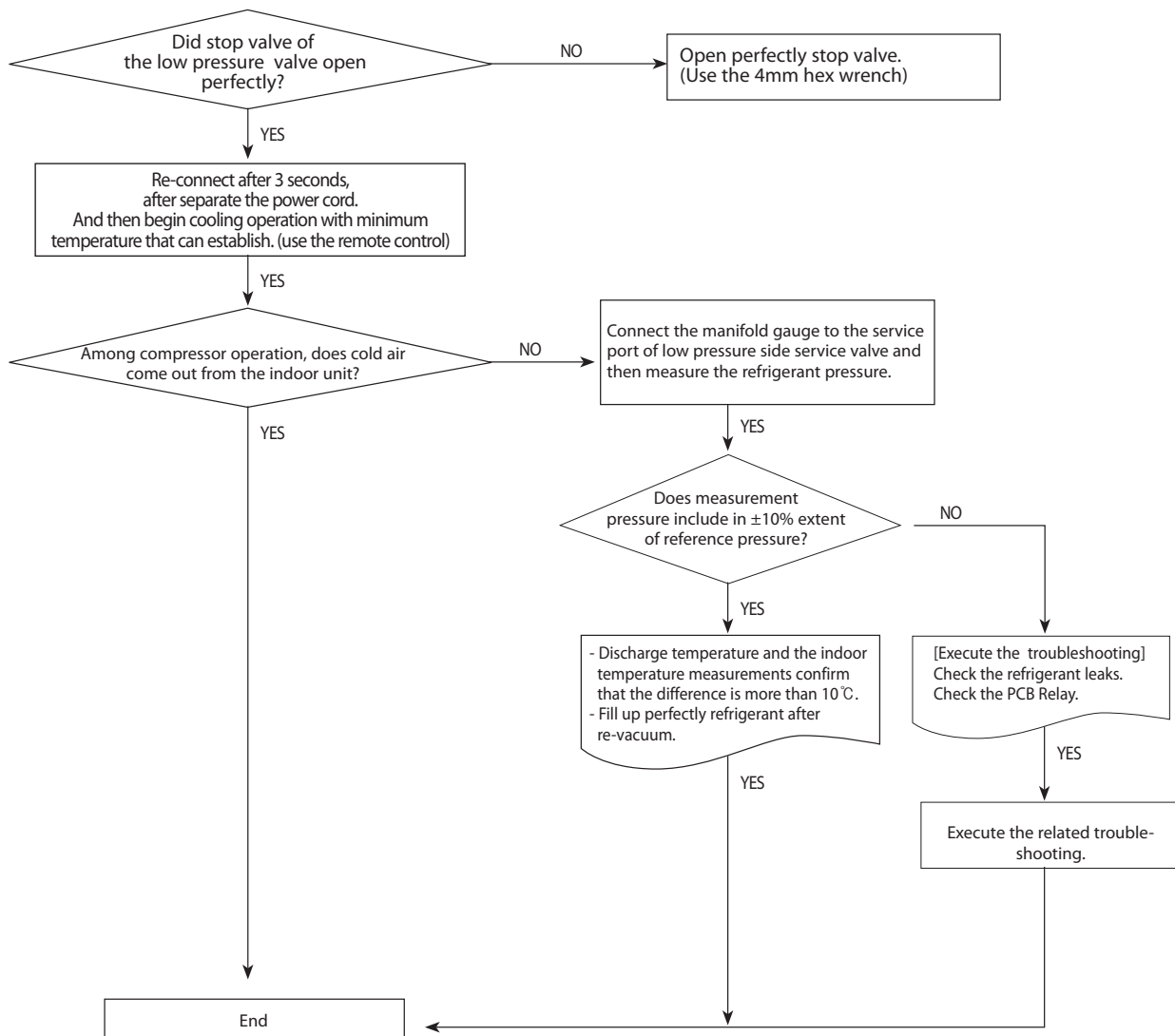

10-3 PCB Inspection Method

10-3-1 Pre-inspection Notices

1. Check if you pulled out the AC power plug when you eliminate the PCB or front panel.
2. Don't hold the PCB side not impose excessive force on it to eliminate the PCB.
3. Don't pull the lead wire but hold the whole housing to connect or disconnect a connector to the PCB.
4. In case of outdoor PCB disassembly, check first the complete discharge of condenser after 1 minute power off.

10-3-2 Inspection procedure

1. Check connector connection and peeling of PCB or bronze coating pattern when you think the PCB is broken.
2. The PCB is composed of 3 parts.
 - . Indoor Main part : MICOM and surrounding circuit, relay, fan motor sensing and driving circuit, temperature sensing circuit power circuit of SMPS, buzzer circuit. Communication circuit.
 - . Display part : LED lamp, Switch, Remote-control module.
 - . Outdoor Main part : MICOM and surround circuit, fan motor sensing and driving circuit, compressor driving circuit power circuit of SMPS, PFC control circuit, 4way circuit, communication circuit, OPTION.(EEV control circuit, temperature sensing circuit)

10-3-3 Indoor detailed inspection procedure

No	procedure	Inspection Method	Cause
1	Plug out and pull the PCB out of the control box Check the PCB fuse.	1) Is 1st fuse disconnected? 2) Is 2nd fuse disconnected?	. Over current. . Indoor Fan motor short. . AC part and pattern short of Indoor PBA.
2	Supply power If the operating lamp twinkles at this time , the above 1)~3) have no relation.	Check the power voltage	
		1) Is the BD71 input voltage 200Vac ~240Vac?	. Power cord is fault, Fuse open, Wrong Power cable Wiring, AC part is faulty.
		2) Is the voltage between both terminal of C111(+)-(-) 12Vdc?	. Switching Trans of Power circuit is faulty.
		3) Is the voltage between both terminal of C118(+)-(-) 5Vdc?	. Power circuit is faulty, Load short.
3	Press the ON/OFF button. 1. Fan speed(high) 2. Continuous Operation	1) Is the voltage over DC 270V being imposed on terminal #1~#3 of fanmotor connector(CN72)?	. Fan motor of the indoor is faulty.
		2) The fan motor of the indoor unit doesn't run.	. Fan motor connector(CN72) is faulty.
		3) The power voltage between terminal #1-#3 of the connector(CN72) is 0V.	. PBA is faulty.

■ New Function [Indoor Terminal Block Safety Device]

1. Thermal Fuse is installed in Terminal Block as below.

(Thermal Fuse is used to prevent PL caused by a defective connection of indoor and outdoor units)

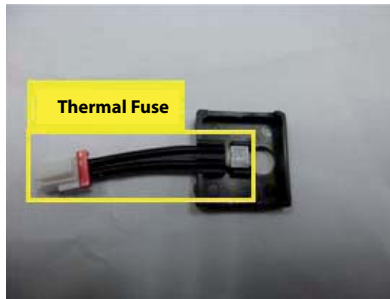

Terminal Block Internals



Connection of terminal block and Main PBA

2. Thermal Fuse is opened when internal temperature of Terminal Block goes to a certain point due to Tracking caused by a defective connection of indoor and outdoor units.

- When Thermal Fuse is opened, Main PBA (DC12V) is turned off and the indoor unit does not operate.
(There is no problem with Main PBA in this case)
- In the above case, the change of all-in-one Terminal Block will make Main PBA operate again.

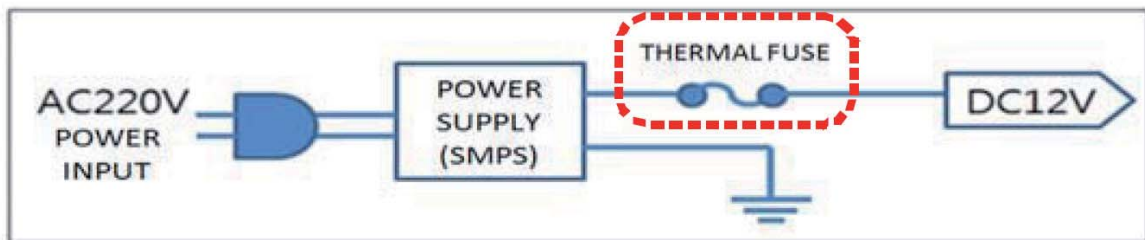

Circuit Block

3. Measurement method of fair/defective thermal fuse



Fair



Defective

10-4 ASSY WIFI KIT Inspection Method

10-4-1 Status-LED Blinking with interval 0.5s

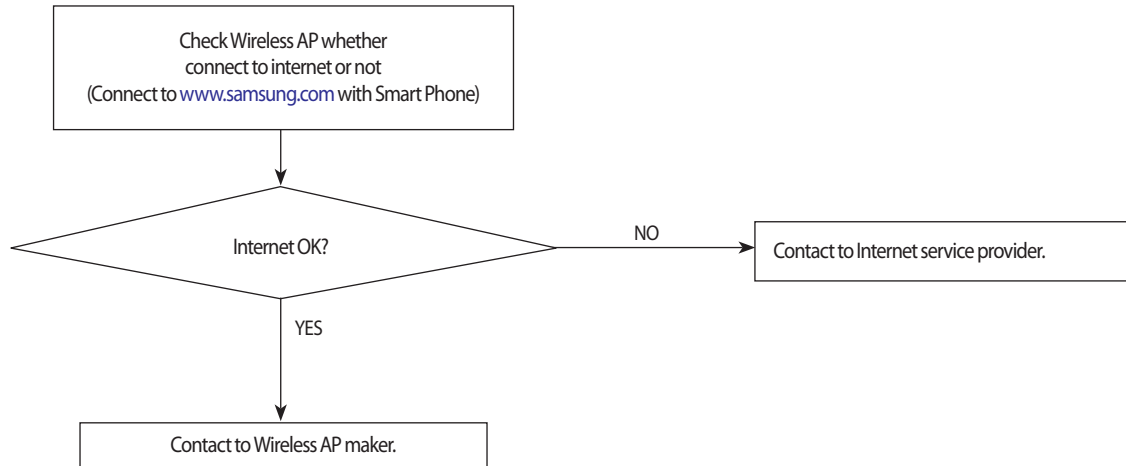

10-4-2 Status-LED Blinking with interval 3s

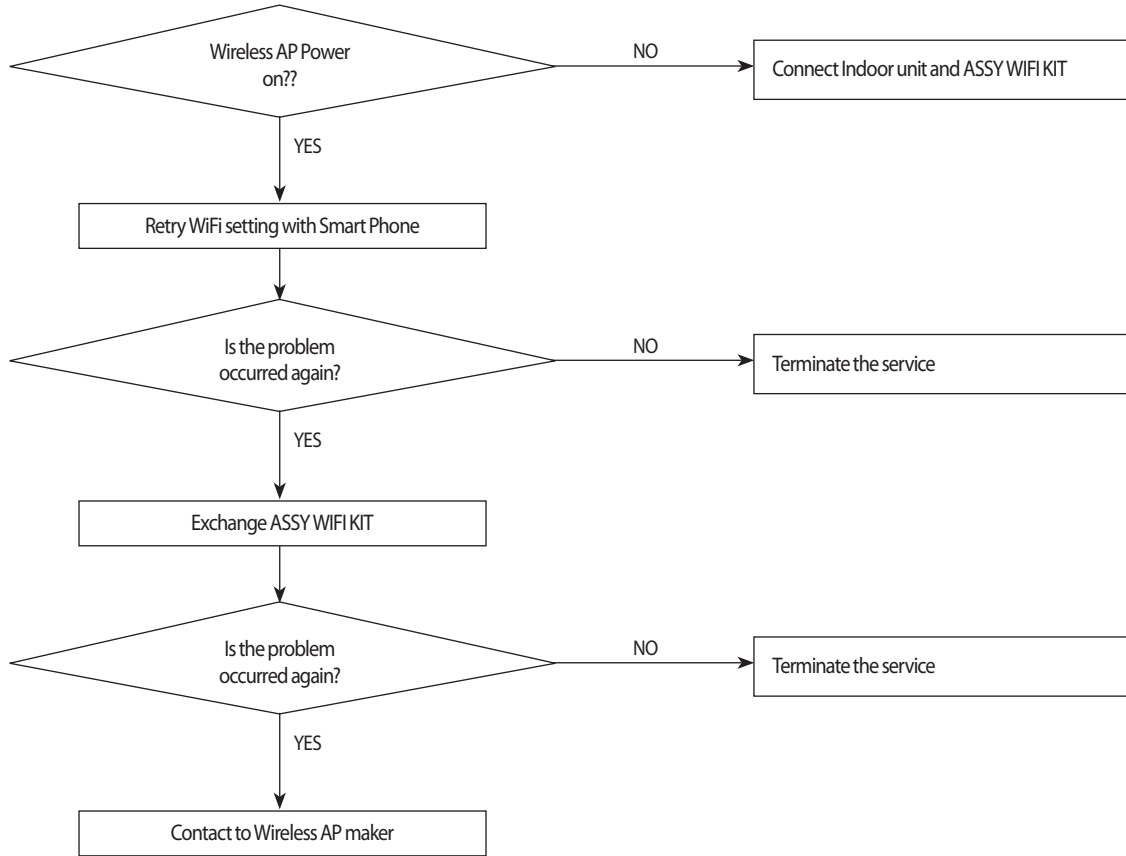

<< **Status LED Indication** >>

- 1. LED ON : Connected with AP & INTERNET
- 2. LED Blinking (Interval of 0.5s) : Connected with AP but not connected with INTERNET
- 3. LED Blinking (Interval of 3s) : Not connected with AP
- 4. LED OFF : Not connected with Air Conditioner

10-4-3 Status-LED OFF

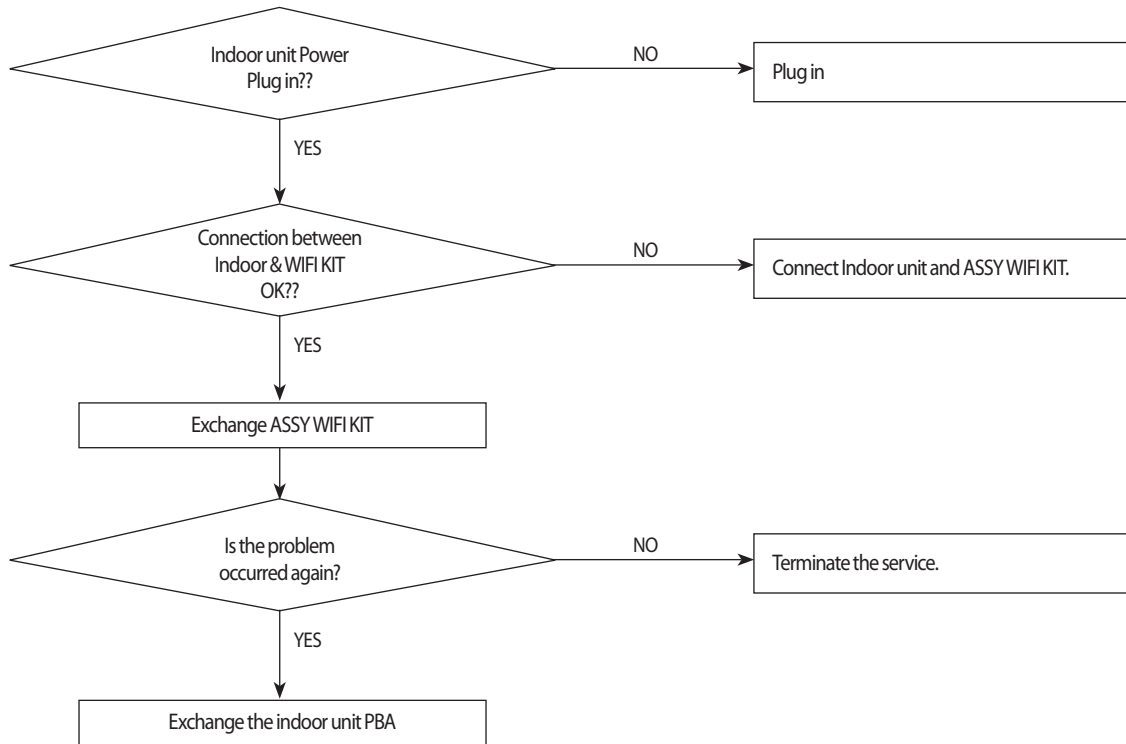

11. Block Diagram

11-1 Indoor unit

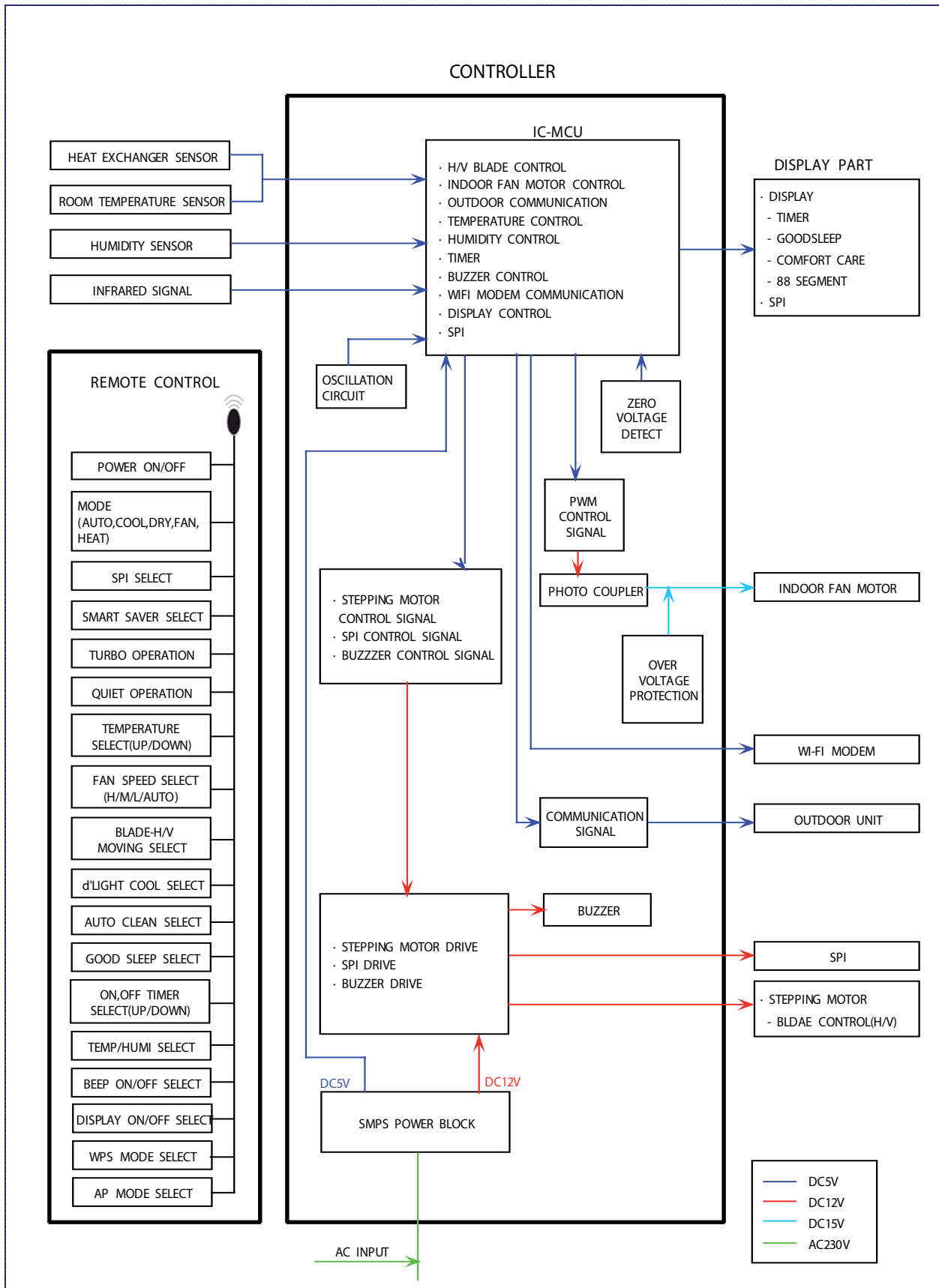

11-2 Outdoor unit

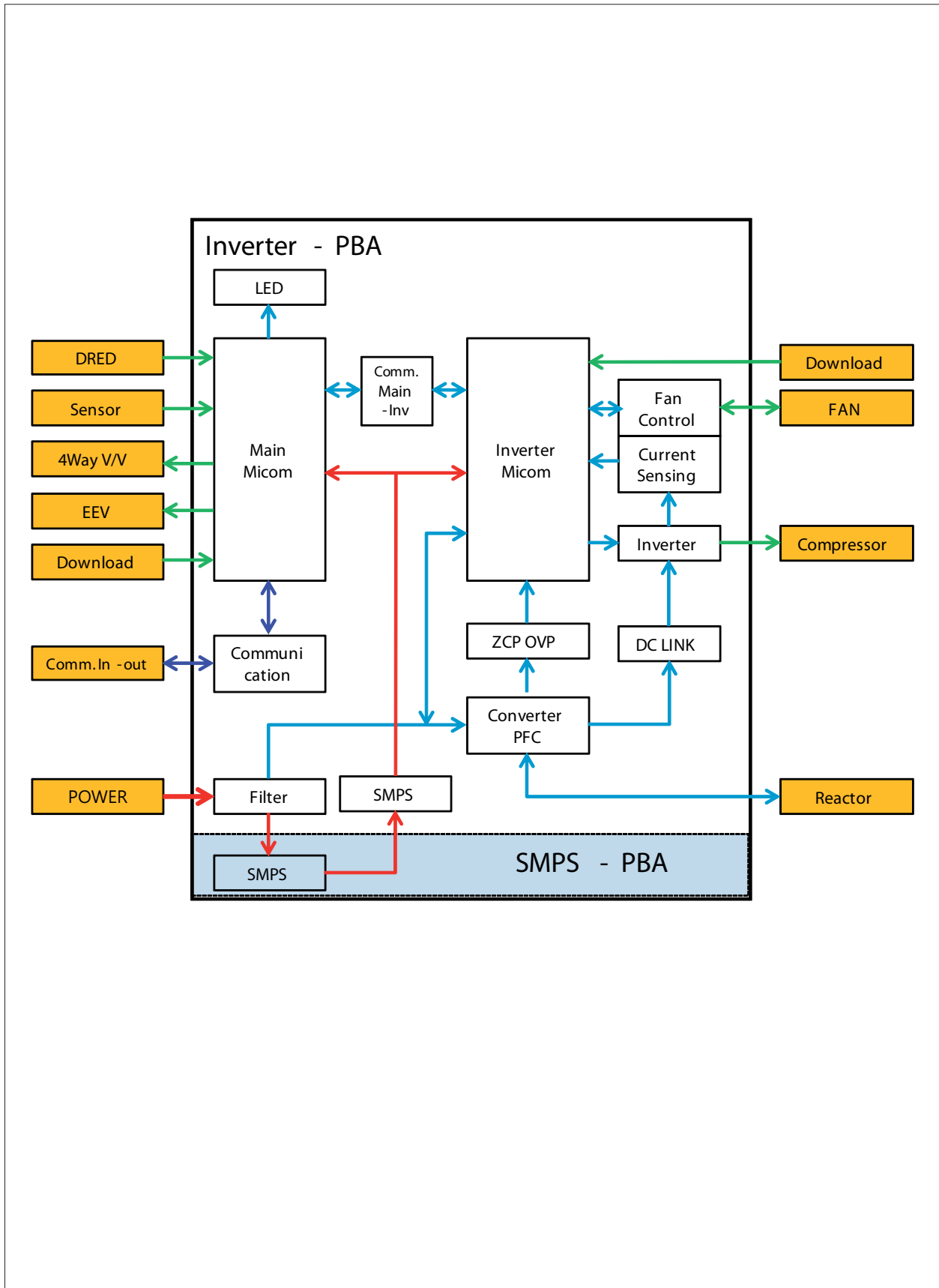

11-2-1 Pre-inspection Notices

1. Check if you pulled out the AC power plug when you eliminate the PCB or front panel
2. Don't hold the PCB side not impose excessive force on it to eliminate the PCB
3. Don't pull the lead wire but hold the whole housing to connect or disconnect a connector to the PCB
4. In case of outdoor PCB disassembly, check first the complete discharge of condenser after 1 minute power off

11-2-2 Inspection procedure

1. Check connector connection and peeling of PCB or bronze coating pattern when you think the PCB is broken
2. The PCB is composed of 3 parts
 - Indoor Main part : MICOM and surrounding circuit, relay, fan motor sensing and driving circuit, temperature sensing circuit power circuit of SMPS, buzzer circuit. Communication circuit
 - Display part : LED lamp, Switch, Remote-control module
 - Outdoor Main part : MICOM and surround circuit, fan motor sensing and driving circuit, compressor driving circuit power circuit of SMPS, PFC control circuit, 4way circuit, communication circuit, OPTION (EEV control circuit, temperature sensing circuit)

11-2-3 Indoor detailed inspection procedure

No	Procedure	Inspection Method	Cause
1	Plug out and pull the PCB out of the control box Check the PCB fuse	1) Is 1st fuse disconnected? 2) Is 2nd fuse disconnected?	. Over current . Indoor Fan motor short . AC part and pattern short of Indoor PBA
2	Supply power If the operating lamp twinkles at this time, the above 1)~3) have no relation	Check the power voltage	
		1) Is the BD71 input voltage 200Vac~240Vac?	. Power cord is fault, Fuse open, Wrong Power cable Wiring, AC part is faulty
		2) Is the voltage between both terminal of IC02 pin #1-#2 12Vdc?	. Switching Trans of Power circuit is faulty
3	Press the ON/OFF button 1. Fan speed(high) 2. Continuous Operation	3) Is the voltage between both terminal of IC02 pin #2-#3 5Vdc?	. Power circuit is faulty, Load short
		1) Is the voltage over AC 180V being imposed on terminal #3-#5 of fan motor connector (CN72)?	. Fan motor of the indoor is faulty
		2) The fan motor of the indoor unit doesn't run	. Fan motor connector(CN72) is faulty
		3) The power voltage between terminal #3-#5 of the connector(CN72) is 0V	. PBA is faulty

11-2-4 Outdoor detailed inspection procedure

No	Procedure	Inspection Method	Cause
1	Plug out and pull the PCB out of the control box Check the PCB fuse (Wait 3 minutes after power off)	1) Is 1st fuse disconnected?	. Over current . AC part and pattern short of Outdoor PBA
2	Check the Wiring	1) Is the Compressor wire connected clockwise? 2) Is the Reactor wire connected normal? 3) Is the Fan wire connected normal? 4) Is the 4way wire connected normal? 5) Is the sensor wire connected normal? 6) Is the EEV wire connected normal?	. Wrong assembly . Installation(service) condition is bad
3	"Supply power and operate the set (Use Remote-control, button in indoor set)"	Check the power voltage	
		1) Is the voltage between Terminal block L-N 200Vac~240Vac?	. Power cord is faulty, Wrong Power cable Wiring
		2) Is the C006 voltage 200Vac~240Vac?	. Fuse open . L,N,F1,F2 wire wrong wiring (Terminal Block-PBA)
		2) Is the CN150 voltage 200Vac~240Vac?	. Power circuit is faulty . Load short
		4) Is the PFC050(#26-#27) voltage 200Vac~240Vac after 3 minutes later?	. Fuse open . L,N,F1,F2 wire wrong wiring (Terminal Block-PBA) . PTC020 open . RY021, RY022 is faulty . Outdoor Micom(IC201) error
		5) Is the CE101 voltage 280Vdc~320dc after 3 minutes later?	. PFC050 is faulty . Reactor wire is wrong connection . Power circuit is faulty, Load short . BLDC Fan motor error
		6) Is the voltage CN151 #1-#2 voltage 15Vdc?	. Switching Trans of Power circuit is faulty . Load short
		7) Is the voltage CN152 #1-#2 voltage 12Vdc?	. Switching Trans of Power circuit is faulty . Load short
		8) Is the voltage CN151 #3-#2 voltage 5Vdc?	. Switching Trans of Power circuit is faulty . Load short
4	Check the LED lamp display	1) Normal : RED on, GRN blink, YEL off 2) Abnormal - All off : check no power - abnormal display : check error mode	. F1,F2 wire wrong wiring . Outdoor PBA is faulty

12. Reference Sheet

12-1 Low Refrigerant Pressure Distribution

Note : Please measure the refrigerant pressure after the air conditioner operates on testing cooling mode during more than 10 minutes.

- Indoor Temp. Variation : 20°C ~ 32°C
- Outdoor Temp. Variation : -5°C ~ 45°C

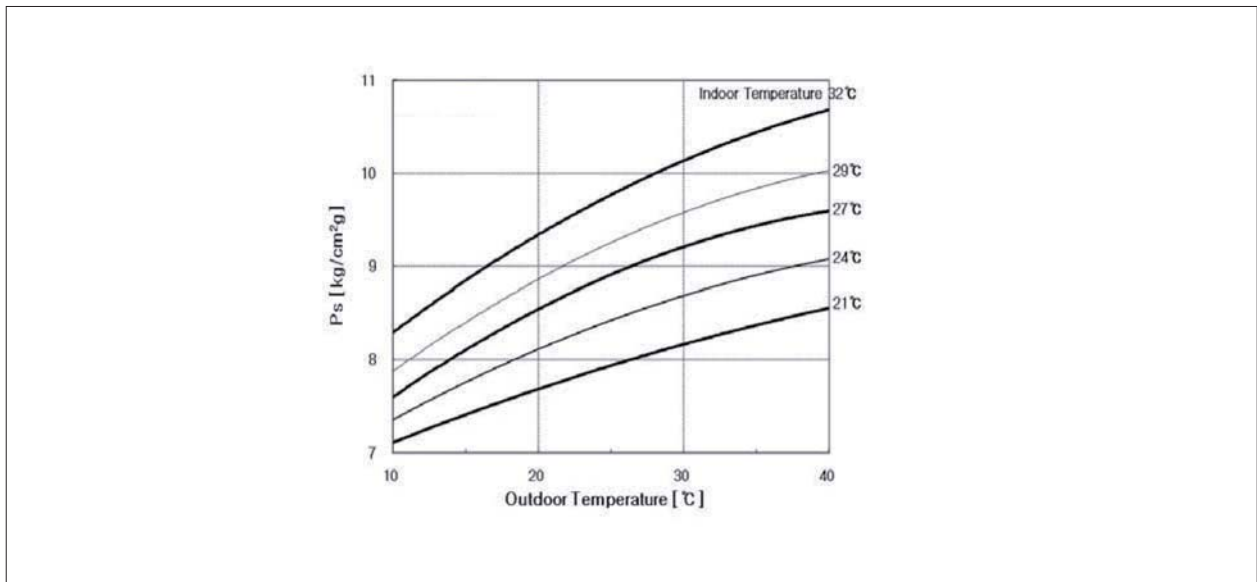

12-2 Pressure & Capacity mark

■ Power/Heat

W	cal/s	kcal/h	Btu/h	HP	kg.m/s	lb.m/s
1	0.23885	0.85985	3.4121	0.001341	0.10197	0.73756
4.1868	1	3.6	14.286	0.0056146	0.42693	3.088
1.163	0.27778	1	3.9683	0.0015596	0.11859	0.85778
0.29307	0.06999	0.252	1	3.9302x10 ⁻⁴	0.029885	0.21616
745.7	178.11	641.19	2,544.4	1	76.04	550
9.8067	2.3423	8.4322	33.462	0.013151	1	7.233
1.3558	0.32383	1.0658	4.6262	0.0018182	0.13826	1

12-3 Q & A for Non-trouble

Classification	Class	Description
Cooling	Q	The cooling is weak.
	A	When it is hot outside, its cooling capacity decreases due to the increase of the ambient temperature. When the dust filter gets blocked or warm outside air gets in, the cooling capacity will decrease. So, make sure to clean the dust filter frequently, prevent heat loss by closing the doors and insulate the cooling area by using curtains, blinds, shades or window tinting.
	Q	The cooling is good generally. But, it gets weak when it is considerably hot.
	A	It occurs when the outdoor unit is exposed to direct sun light and heat-up air is not ventilated well. So, set up a sunblind over the outdoor unit and keep stuff away from the unit to increase the ventilation. When the cooling capacity decreases during a heat wave, clean the heat exchanger of the outdoor unit or spray some cold water to the heat exchanger to increase the cooling capability.
	Q	The cooling is weak. Does it need refrigerant charging?
	A	It is not correct charging refrigerant regularly. Except that you have moved in several times or the connection pipes are broken, the refrigerant does not run low. So, when refrigerant is additionally charged, it could be costly and cause a product's failure. When the refrigerant leaks, all of it will escape in a short time resulting in cooling failure and no water coming out of the drain hose. So, if water comes out from the drain hose, it indicates the normal operation of the product and it does not need refrigerant charging.
	Q	It fails to do cooling.
Leakage	A	When the air conditioner is set to ventilation or the desired temperature is set higher than the current temperature, it fails to do cooling. In this case, select cooling or set the desired temperature lower.
	Q	It floods the floor.
	A	Place the drain hose properly. When it is not placed properly, the drain water would flow back flooding the floor. So, straighten out the drain hose for the water to be drained well.
	Q	Water drips at the drain connection (service valve) of the outdoor unit.
	A	When a glass bottle is taken out of the refrigerator, moisture gets condensed on its surface due to the temperature differences. The same principle applies to the air conditioner. When cold refrigerant goes through the copper tube, moisture gets condensed on the surface of the tube and the connection areas. To prevent the water condensation, the pipes are insulated. But, the connection areas of the outdoor unit are not insulated for the purpose of maintenance or repair, and water gets condensed due to the temperature differences and drips down. Generally, it evaporates right away. But, when it drips much during muggy days, put a water pan on the floor.
	Q	It leaks even though a drain pump is used.
Smells	A	It occurs when the drain pump is plugged out or it is out of order. Check the power of the drain pump and the position of the drain hose, and when the pump is faulty, contact the drain pump manufacturer. Samsung Electronics do not manufacture drain pumps. So, we are not able to correct the drain pump problems.
	Q	Whenever the air conditioner is turned on, it irritates my eyes and gives me a headache.
Smells	A	There are no components in the air conditioner irritating the eyes and sending out chemical smells. But, when the air conditioner is turned on, other smell sources are sucked into the air conditioner and get out of it. So find and root out the smell sources. Generally, it occurs at a interior renovated place, a pharmacy, a gasoline handling place, a tire shop, a second-hand book shop or an electronic component handling place, when its chemical or musty smells are sucked in and sent out, it can be misled that the air conditioner generates them.

Classification	Class	Description
Smells	Q	Whenever the air conditioner is turned on, it stinks.
	A	When are no components in the air conditioner sending out chemical smells. But, when the air conditioner is turned on, other smell sources are sucked into the air conditioner and get out of it. So, find and root out the smell sources. Generally, when the drain hose is taken out to the washing room or there are sources of smells such as a diaper bin, a shoe shelf or a socks bin, bad smells generate. Also, it occurs where glass cleaners or air fresheners are used; when they are sucked in interacting with dusts and moistures inside, bad smells generate. these kinds of organic materials noxious to human bodies. So, we recommend against the use of them.
	Q	Whenever the air conditioner is turned on, it smells sour.
	A	When the room is papered recently, its paste smells would be sucked inside. Also, when the air conditioner is installed in the study room of young boys loving sweat-generating activities such as the basketball, excessive sweats evaporate and get sucked into the air conditioner resulting in bad smells. So, find and root out problem or refresh the room frequently.
	Q	Whenever the air conditioner is turned on, it smells musty.
	A	It is due to the improper keeping of the product after its use. When keeping the product, dry up the inside with the operation of ventilation to prevent must. When the product is kept without drying up the inside with ventilation, mold would grow inside resulting in must. So, open the windows and switch on the ventilation function to get rid of the saturated smell inside.
	Q	Whenever the air conditioner is turned on, it sends out bad smells such as stale smells.
	A	It occurs generally when there are pet animals in the house. Their smells stay at the same place. But, when the air conditioner is turned on, the air gets circulated resulting in the circulation of the smells. So, find and root out the problem or refresh the room frequently.
	Q	It sends out bad smells.
A	When the air filter is filthy, it could send out bad smells. So, clean the filter and ventilate the room with the windows open while operating the ventilation function.	
Operation	Q	It won't start.
	A	There is a power failure or it is plugged out. Also, check if the power distribution panel is switched off.
	Q	It goes off during operation.
	A	When the hot air does not escape properly, it goes off during operation. it occurs when it does not ventilate properly because the outdoor unit is covered, the back of the outdoor unit is blocked by a cardboard or a plywood panel, and the front of the outdoor unit is blocked by the closed window or other obstacles. Clear the above obstacles from the outdoor unit.
	Q	It generally works properly. But, when it's considerably hot, it goes off during operation.
	A	It occurs when the outdoor unit is exposed to direct sunlight and the hot air does not escape properly. Set up a sun blind over the outdoor unit and clear the neighboring obstacles from the outdoor unit to provide good ventilation. When it goes off frequently during a heat wave, it would prevent the turn-off and increase the cooling capacity cleaning the outdoor unit or spraying some water to the heat exchanger.
	Q	The remote controller won't operate.
A	When the batteries run out or the transmitter or receiver of the remote controller is blocked by obstacles, change the batteries or keep the obstacles away from the controlling area. Also, the remote controller may not work under intensive light from a 3-wave length lamp or a neon sign due to the EMI. In this case, take the remote controller closer to the receiver.	

Classification	Class	Description
Installation	Q	Who installs the air conditioner? (Relocation/Re-installation)
	A	When relocating or re-installing the air conditioner, make sure to contact Samsung Electronics Service Center or Authorized Service Agent and have them to do the job. (If not, it could cause personal injury or product damage.) The cost for the relocation/re-installation of the air conditioner is subject to the customer's expense. There is a cost table. But, our service engineer needs to visit to total up the cost correctly. When you move in, make sure to contact Samsung Electronics Service Center or Authorized Service Agent in advance to streamline the process.
	Q	Is it possible to install the outdoor unit outside?
	A	It is possible to install it at a designated place in the apartment or on the rooftop nearby. But, it's illegal hanging an angle iron case with the outdoor unit in it outside the apartment. Also, it is illegal obstructing passers-by with the outdoor unit installed outside.
	Q	What can be done to install the outdoor unit facing the road because it is a commercial building?
	A	The following is an excerpt from building code going into effect from JUNE 1 st 2005. "The exhaust pipe of a cooling or ventilation facility installed in a building adjacent to the streets of commercial or residential areas shall be installed higher than 2 m to prevent the exhaust air from blowing directly to passers-by and the current facilities shall be corrected by MAY 31 st 2005." So, please install it higher than 2 m or not to blow the hot exhausting air directly to passers-by.
	Q	What about installing a windscreen during installation not to blow hot air directly to passers-by?
A	When the hot air from the front of the outdoor unit is blocked, the product's performance will be affected and it will fail to operate properly. So, keep it at least 300mm away from its surrounding walls and give it good ventilation.	

12-4 Cleaning /Filter Change

12-4-1 Cleaning your Air Conditioner

To get the best possible use out of your air conditioner, you must clean it regularly to remove the dust that accumulates on the air filter.

Removing the Air filter

There is a hole on the bottom right side of the filter. Put your finger in that hole to get a grip on the filter and slightly push it up to release the hooks from the bottom side. Then, pull it down to remove the filter from the main body.

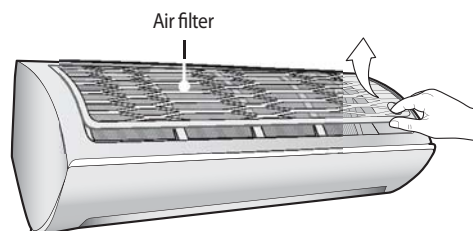

Cleaning the air filter

Washable foam based air filter captures large particles from the air. The filter is cleaned with a vacuum or by hand washing.

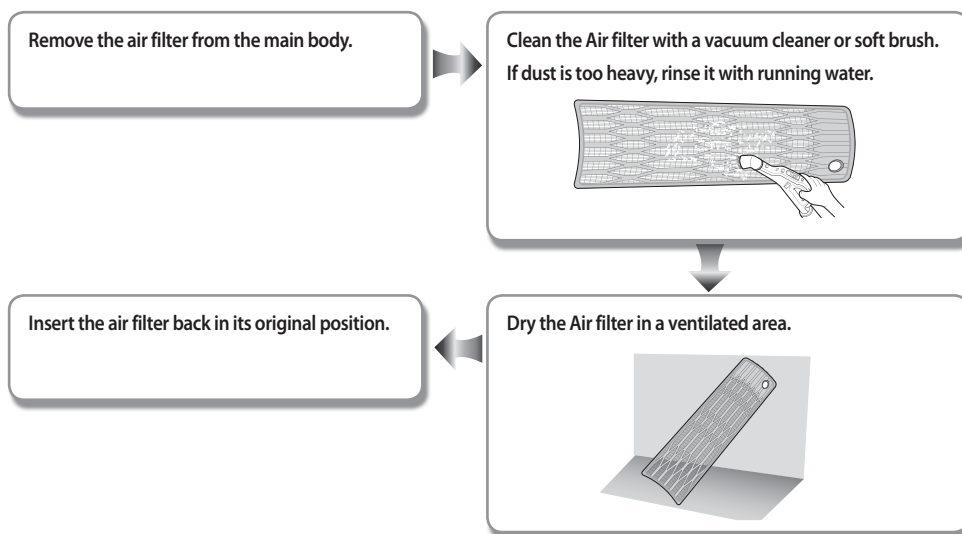

- Clean the Air filter every 2 weeks. Cleaning term may differ depending on the usage and environmental conditions. In dusty area, clean it once a week.
- If the Air filter dries in a confined (or humid) area, odors may generate. If it occurs, re-clean and dry it in a well-ventilated area.
- When the filter clean reminder is on, please press the 2nd F button and then press the ECO Run button on remote controller.

12-5 Installation

12-5-1 Before Installation

Keep the air conditioner outlet and inlet free from its surroundings.
In case of installation, keep the symmetry and fix it to prevent vibration.
The pipe length shall meet the standard as far as possible.

12-5-2 Installation Procedure

■ Location

Install the product in an area to guarantee the best cooling effect, convenience of piping and electric work, and inexistence of vibration or wind.

■ Wall Drilling

Drill the wall downward in a diameter of 60 to 65mm.

■ Fixing Indoor Unit & Outdoor Unit

Fix the air conditioner indoor unit securely to the wall. Secure the outdoor unit in a suitable position.

■ Pipe Spooling & Connecting

You shall cut the pipe with a pipe cutter and grind all the burrs of the cut surface.
pipe expansion may continue until the pipe surface becomes uneven or torn apart.
Be sure to use a torque wrench to tighten pipes or flare nuts.

<Torque & Depth>

Outer Diameter (D)	Torque(kgf-cm)	Depth(A)
ø6.35 mm(1/4")	140~170	1.3 mm
ø9.52 mm(3/8")	250~280	1.8 mm
ø12.70 mm(1/2")	380~420	2.0 mm
ø15.88 mm(5/8")	440~480	2.2 mm
ø19.05 mm(4/4")	9900~1,210	2.2 mm

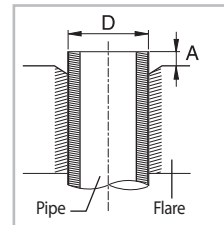

■ Leak Test

Put an inset gas like nitrogen in the outdoor unit pipe and put soap bubbles or other test liquids on the pipe surface for the leak test.

■ Drain Hose Connecting

Install the drain hose downward to drain water naturally. Be sure to pour water into the hose to check if it drains well.

■ Electric & Earth Work

Electric and earth work shall meet the "Electric Facility Technology Standard" and the "Internal Wire Regulation" of the Electric Business Laws.

■ Inspection & Trial Run

Upon completion of the tests, you shall make a trial run while you explain the main functions of the air conditioner to finish the installation.

12-6 Installation Diagram of Indoor Unit and Outdoor Unit

12-6-1 Air-Purge Procedure

1) Connect each assembly pipe to the appropriate valve on the outdoor unit and tighten the flare nut.



2) Connect the charging hose of low pressure side of manifold gauge to the packed valve having a service port (3/8" Packed valve) as shown at the figure.



3) Open the valve of the low pressure side of manifold gauge counter-clockwise.



4) Purge the air from the system using vacuum pump for about 30 minutes.
 - After that, please recheck that pressure is stabilized.
 - Close the valve of the low pressure side of manifold gauge clockwise.
 - Remove the hose of the low pressure side of manifold gauge.



5) Set valve cork of both liquid side and gas side of packed valve to the open position.



6) Mount the valve stem nuts to the 2 way and 3 way valve. And mount the service port cap to 3 way valve.



7) Check for gas leakage.
 - At this time, especially check for gas leakage from the 3 way valve's stem nuts, and from the service port cap.

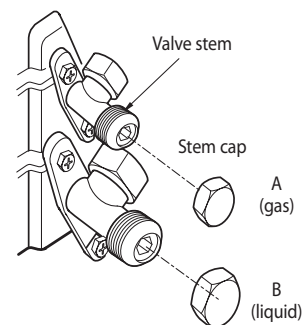
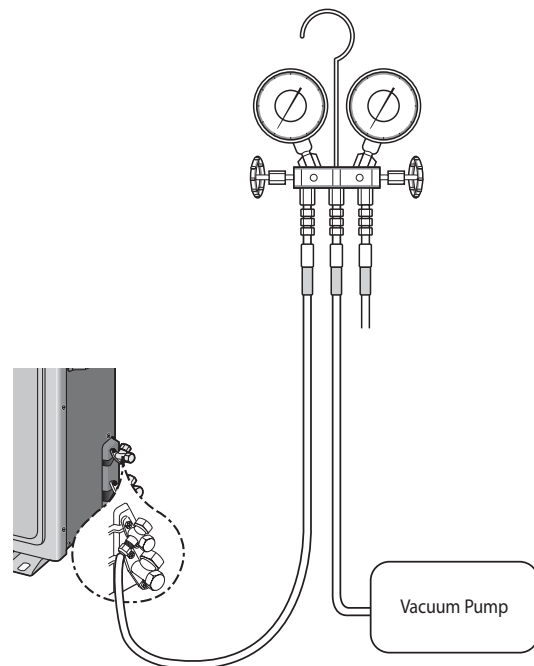
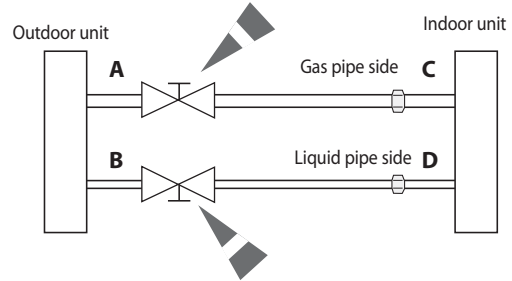

12-6-2 "Pump down" Procedure

Pump down will be carried out when an evaporator is replaced or when the unit is relocated in another area.

1) Remove the caps from the 3 way valve and the 3 way valve.



2) Turn the 3 way valve clockwise to close and connect a pressure gauge (low pressure side) to the service valve, and open the 3 way valve again.



3) Set the unit to cool operation mode.
(Check if the compressor is operating.)



4) Turn the 3 way valve clockwise to close.



5) When the pressure gauge indicates "0" turn the 3 way valve clockwise to close.



6) Stop operation of the air conditioner.



7) Close the cap of each valve.

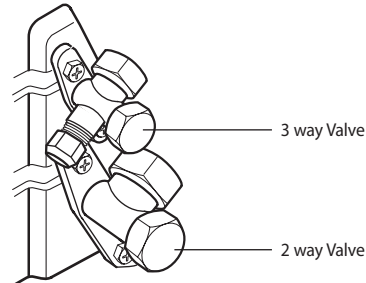

Remarks

Relocation of the air conditioner

- Refer to this procedure when the unit is relocated.
- Carry out the pump down procedure (refer to the details of 'pump down').
- Remove the power cord.
- Disconnect the assembly cable from the indoor and outdoor units.
- Remove the flare nut connecting the indoor unit and the pipe.
- At this time, cover the pipe of the indoor unit and the other pipe using a cap or vinyl plug to avoid foreign material entering.
- Disconnect the pipe connected to the outdoor unit.
At this time, cover the valve of the outdoor unit and the other pipe using a cap or vinyl plug to avoid foreign material entering.
- Make sure you do not bend the connection pipes in the middle and store together with the cables.
- Move the indoor and outdoor units to a new location.
- Remove the mounting plate for the indoor unit and move it to a new location.

12 - 7 WORKING RANGE

Cooling

Item	Lower (°C)	Upper (°C)	Rated (°C)
Outdoor	-10	46	35
Indoor	16	32	27

Heating

Item	Lower (°C)	Upper (°C)	Rated (°C)
Outdoor	-25	24	7
Indoor	8	27	20

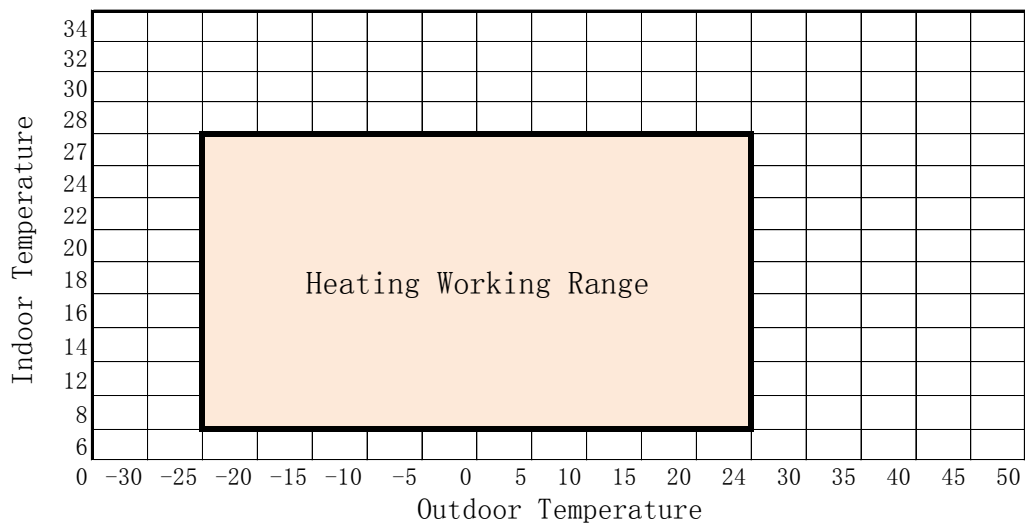
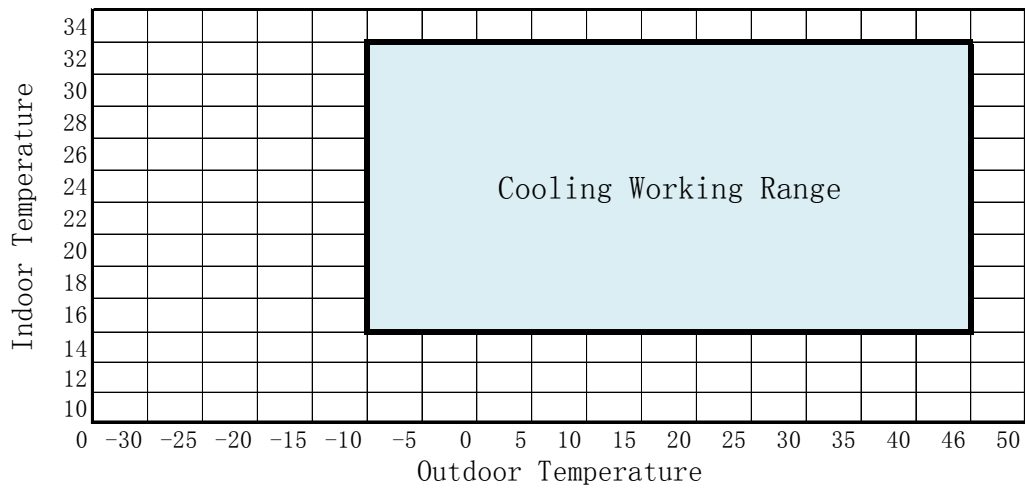

12-8 Reference Sheet

Index for Model Name

* Project model code for overseas from 2007(For RAC Export Models)

Model Code

1st	2nd	3rd	4th	5th	6th	7th	8th	9th	10th	11th	12th	13th	14th
Project		Capacity		Sell	Feature		Series		Color		Unit	Export	
A	R	1	2	F	S	S	S	B	W	K	N/X	S	A

ITEM	1ST	2ND
RAC	A	R
FAC	A	F
WAC	A	W

Item	Reference	3TH	4TH
1	Export	0	9
2	Export	1	2
3	Export	1	8
4	Export	2	4
5	Export	3	0

Item	5TH
12Year	E
13Year	F
14Year	H
15Year	J
16Year	K

Item	6TH
INVERTER HP	S
INVERTER CO	V

Item1	Item2	7TH
Export	The virus doctor (The India / Latin America A / PAC K besides)	S
Export	NO virus doctor (the India / Latin America A / PAC K besides)	F

Special instructions:
About AR**FSSSCUR/SA, the 7TH is "S", but there is no virus doctor in these models.

9TH DIGIT		
Export	1st MODEL	A
Export	2nd MODEL	B
Export	3rd MODEL	C
...
Export	14rd MODEL	P

Item 1	Item 2	Item 3	8TH	9TH
Export	RAC	FMC FLG (Best)	1ST MODEL	F
Export	RAC	FMC DLX (Better)	1ST MODEL	D
Export	RAC	FMC STD (Good1)	1ST MODEL	S
Export	RAC	FMC ENT (Good2)	1ST MODEL	N

Division	Series	Project	Color Name	Division component	Sinkeolreo code (10TH,11TH)	Remark
A3050	F	Best	Twilight	Grille	WK	
	F	Best	TBD	Grille	TBD	
	D	Better	Twilight	Grille	WK	
	D	Better	TBD	Grille	TBD	
	S	Good1	Twilight	Grille	WK	Deco : Transparency
	S	Good1	Midnight Blue	Deco	UR	Grille : Twilight
	N	Good2	Twilight	Grille	WK	
	N	Good2	TBD	Grille	TBD	Grille : Metallic Gray

Item1	Item2	12TH
Export	SET	/
Export	IN	N
Export	OUT	X

Item	The existing code	The sales area	CIS Description	The integrated code (13TH,14TH)
1	XEE	SWEDEN	SWEDEN(XEE)	EE

● Except the RAC Export Models for China.



GSPN (GLOBAL SERVICE PARTNER NETWORK)

Area	Web Site
Europe, CIS, Mideast & Africa	gspn1.samsungcsportal.com
Asia	gspn2.samsungcsportal.com
North & Latin America	gspn3.samsungcsportal.com
China	china.samsungportal.com

This Service Manual is a property of Samsung Electronics Co., Ltd.
Any unauthorized use of Manual can be punished under applicable
International and/or domestic law.

© Samsung Electronics Co., Ltd. August. 2013.
Code No. AC-00045K_1